

# 24GHz Low Power UWB Compact TX/RX MMIC Design

Chi Jeon Hwang

1<sup>st</sup> Supervisor : Khaled Elgaid

2<sup>nd</sup> Supervisor : Iain Thayne

University of Glasgow

[cjhwang@elec.gla.ac.uk](mailto:cjhwang@elec.gla.ac.uk)



- 24GHz Low Power RF Transceiver Configuration
- VCO Design
- IQ Mixer Configuration
- Mixer Design (LO Signal Source Injection)
- 90° Coupler Design
- Power Divider Design
- IQ Mixer Design
- Summary

# 24GHz Low Power RF Transceiver Configuration

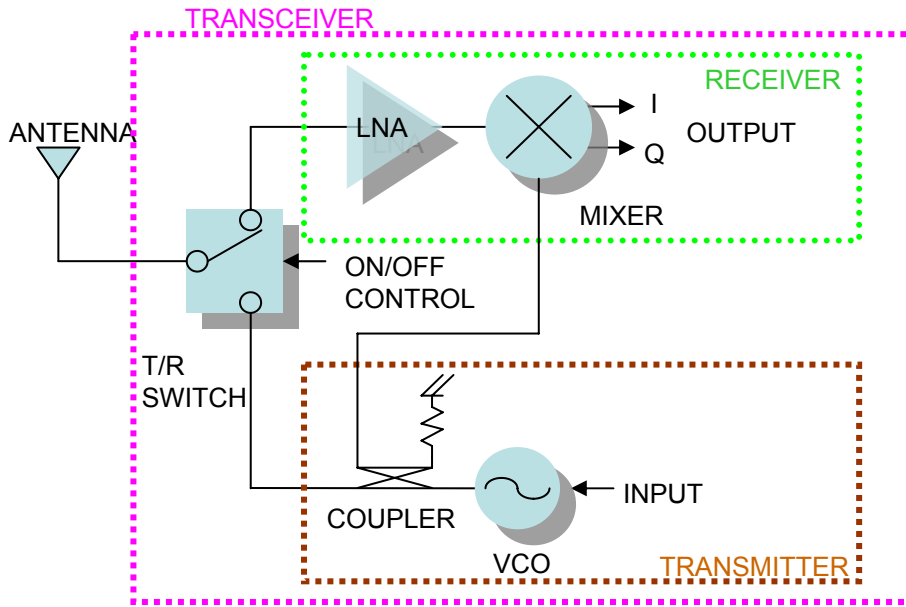

Direct Conversion RF Transceiver (I)

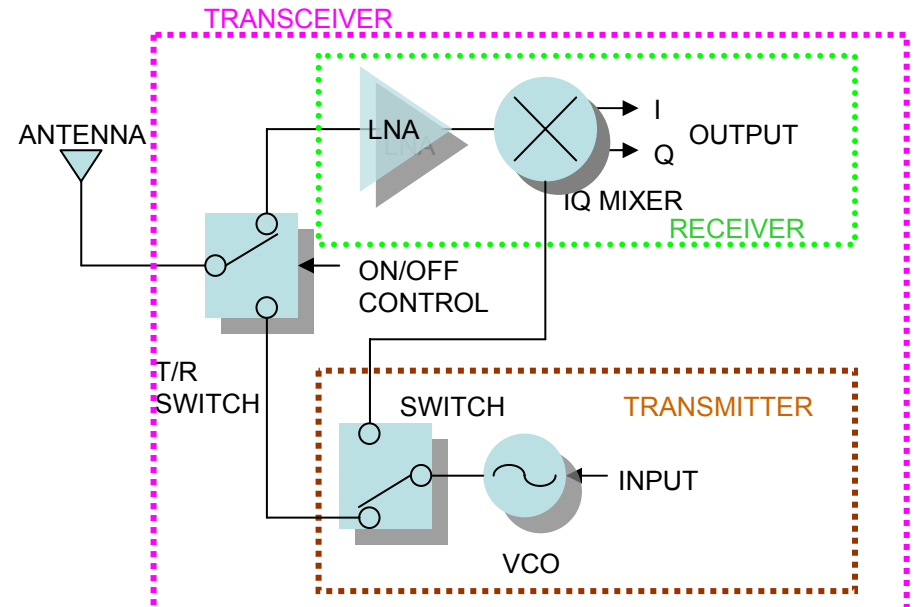

Direct Conversion RF Transceiver (II)

# Voltage Controlled Oscillator (VCO) Design

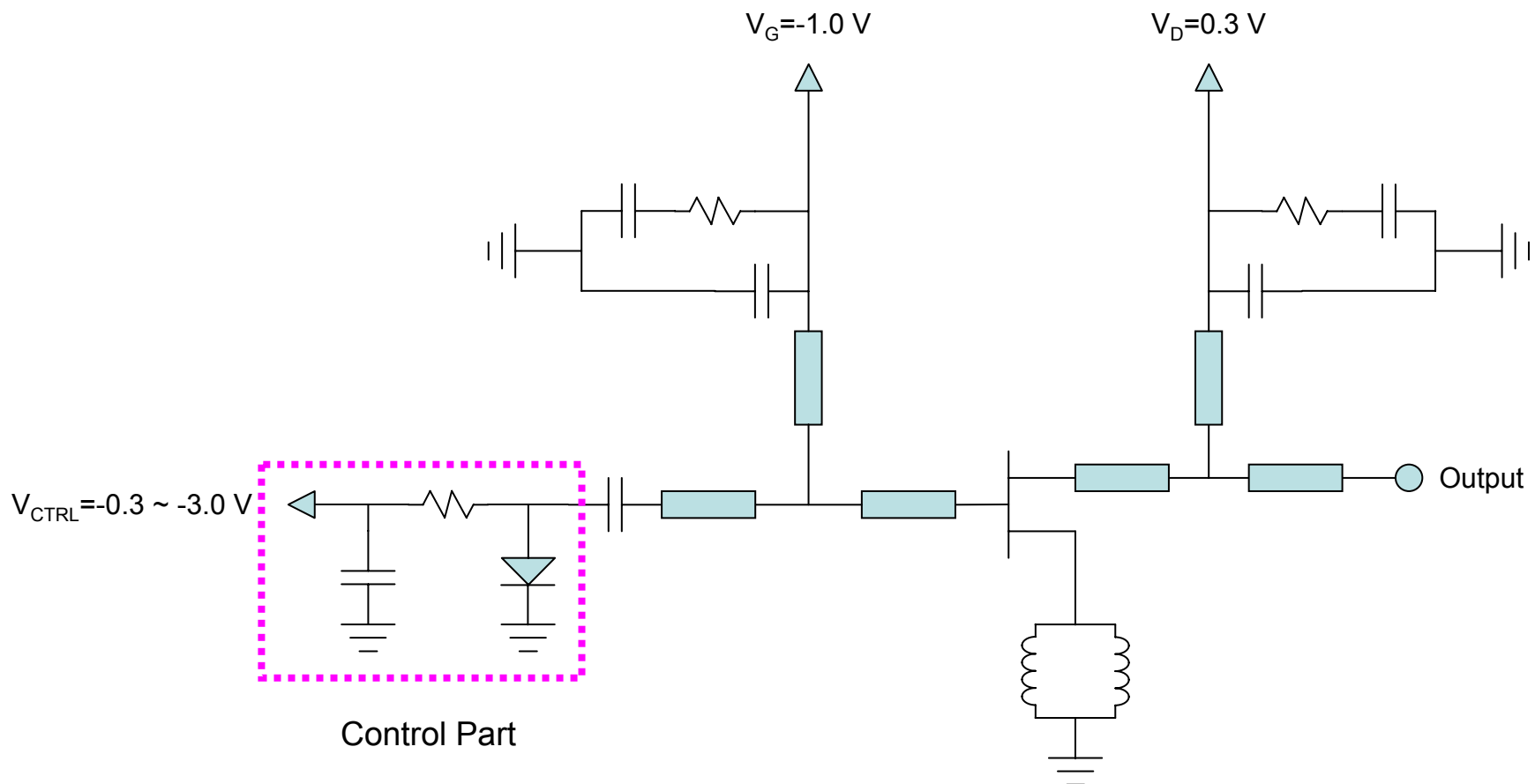

# VCO Design

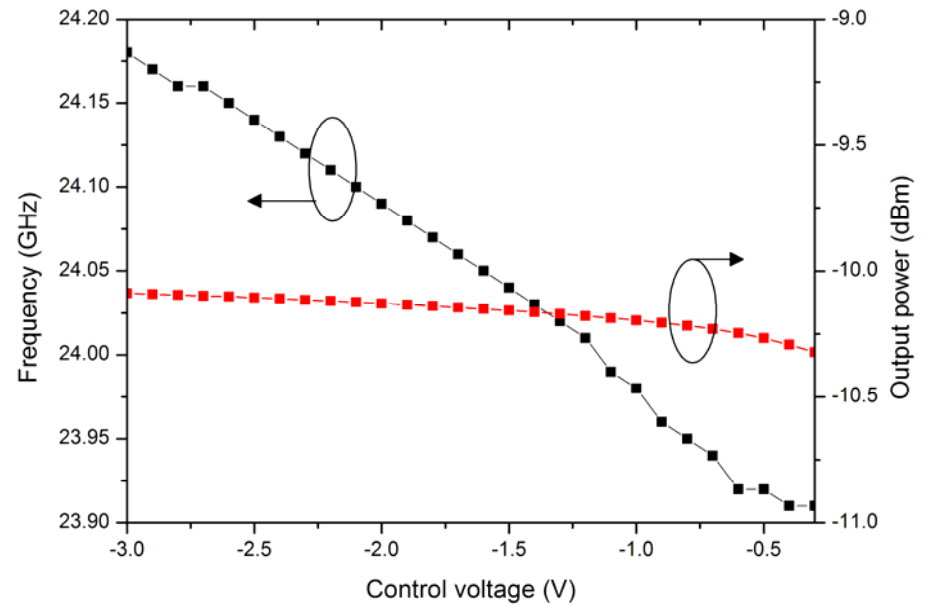
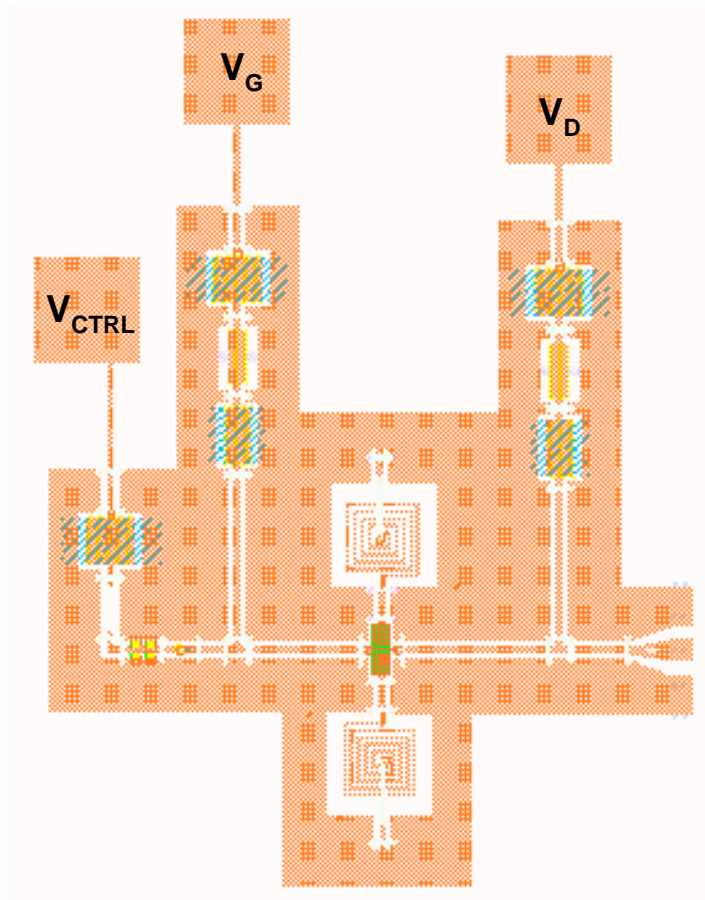

- Controlled Frequency Range : 280MHz
- Output Power Level : -10dBm
- Power Consumption : 0.6mW ( $V_d=0.3V$ ,  $I_d=1.9mA$ )

# IQ Mixer Configuration

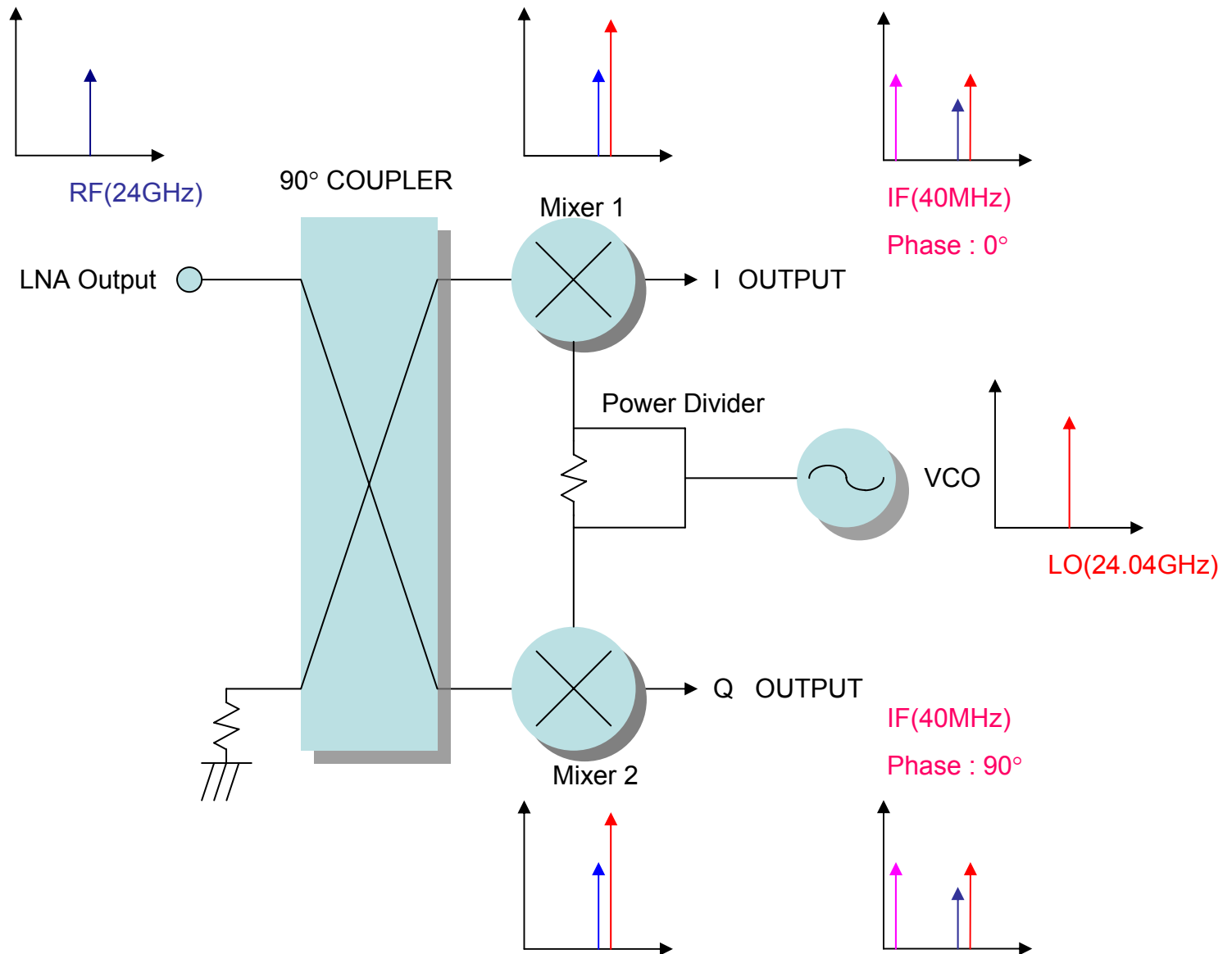

# Mixer Design (LO Signal Source Injection)

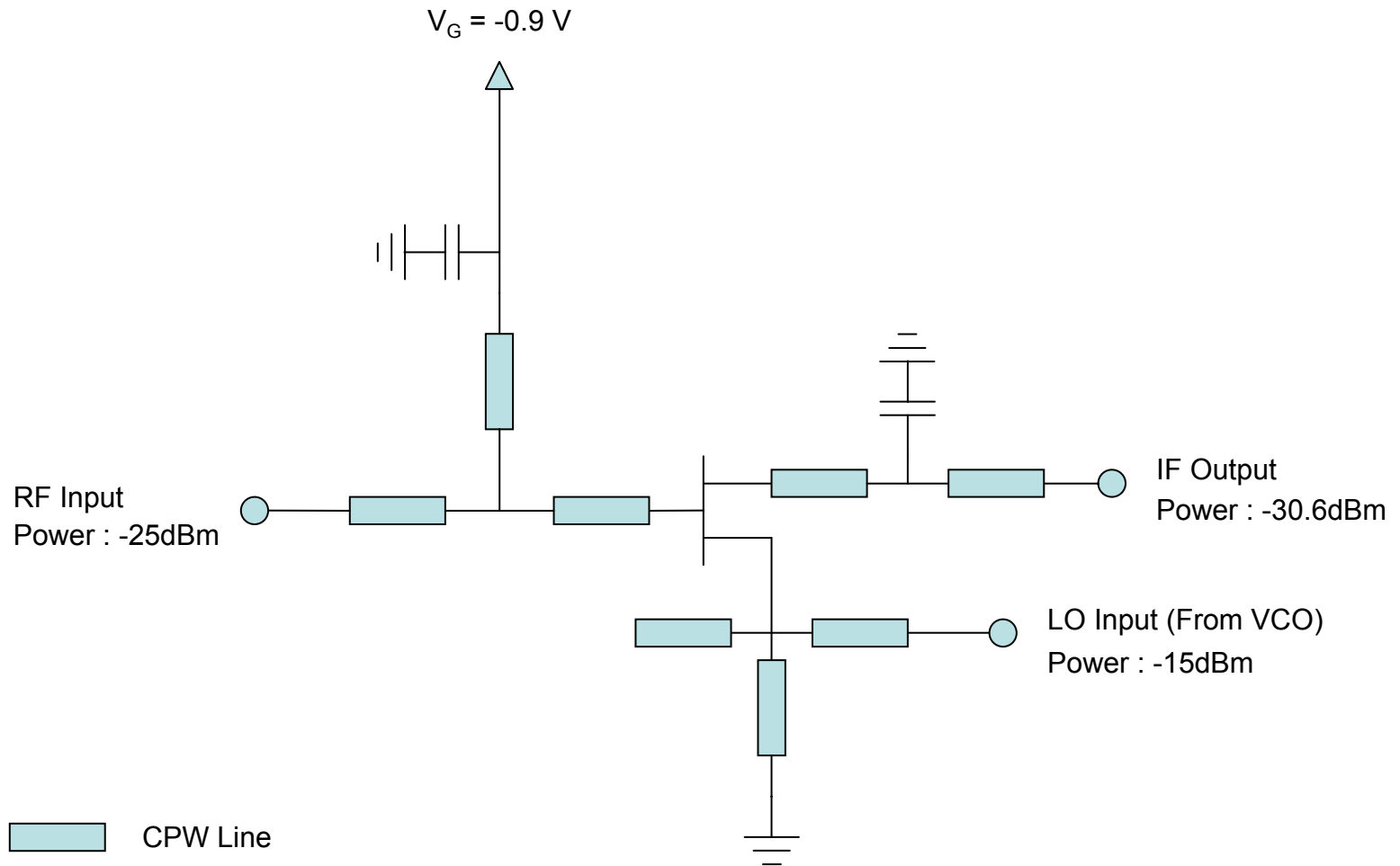

# Mixer Design (LO Signal Source Injection)

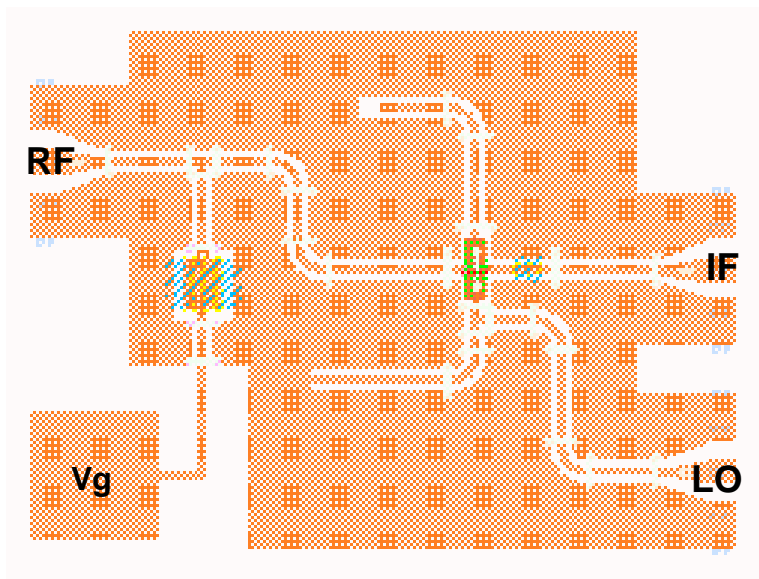

RF Frequency & Power : 24GHz, -25dBm

LO Frequency & Power : 24.04 GHz, -15dBm

IF Freq. (LO-RF) : 24.04GHz – 24GHz = 40 MHz

Conversion Loss ( $P_{IF}-P_{RF}$ ) : -30.6dBm-(-25dBm)=-5.6dB

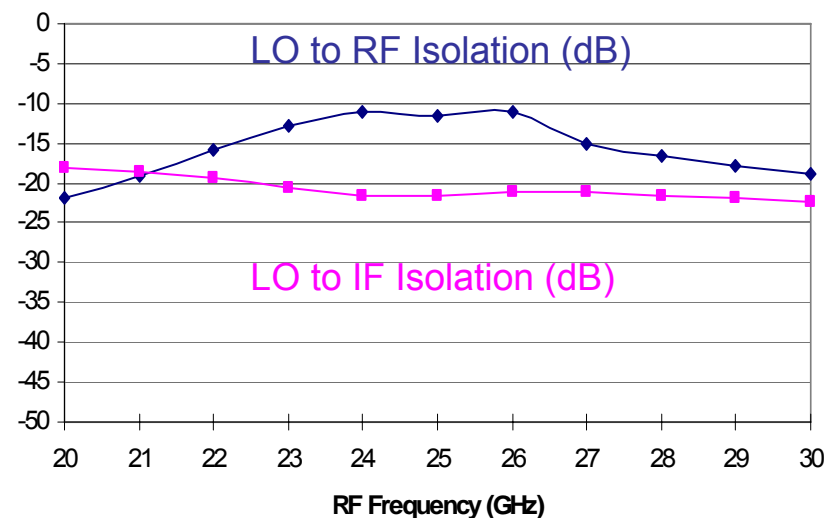
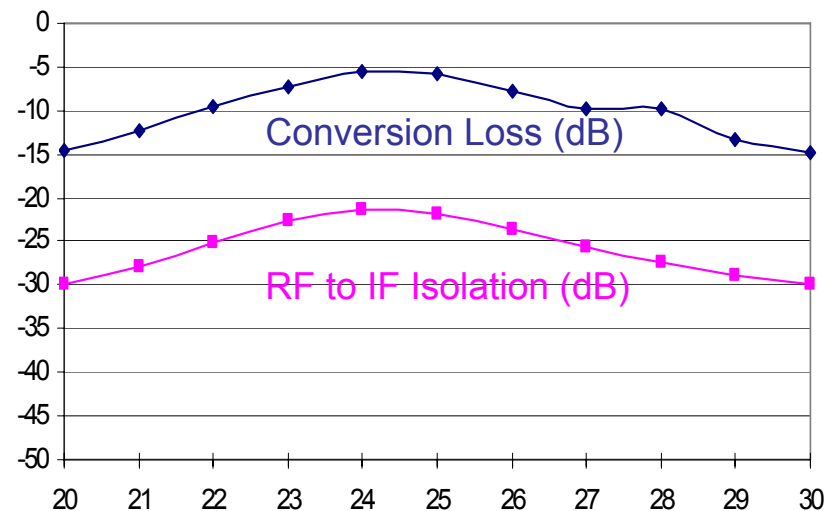

# 90° Coupler Design

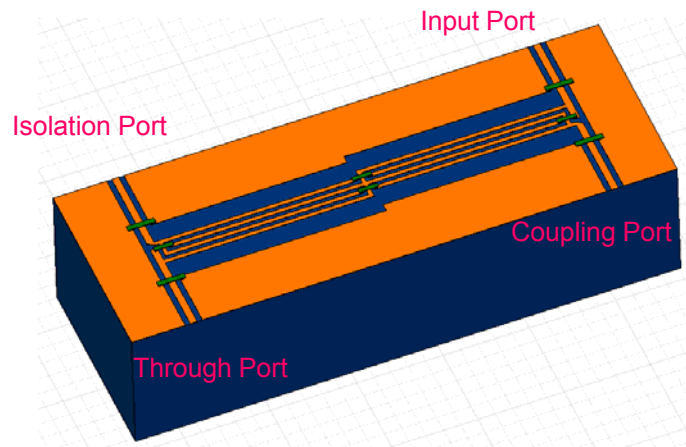

Phase Division (deg)

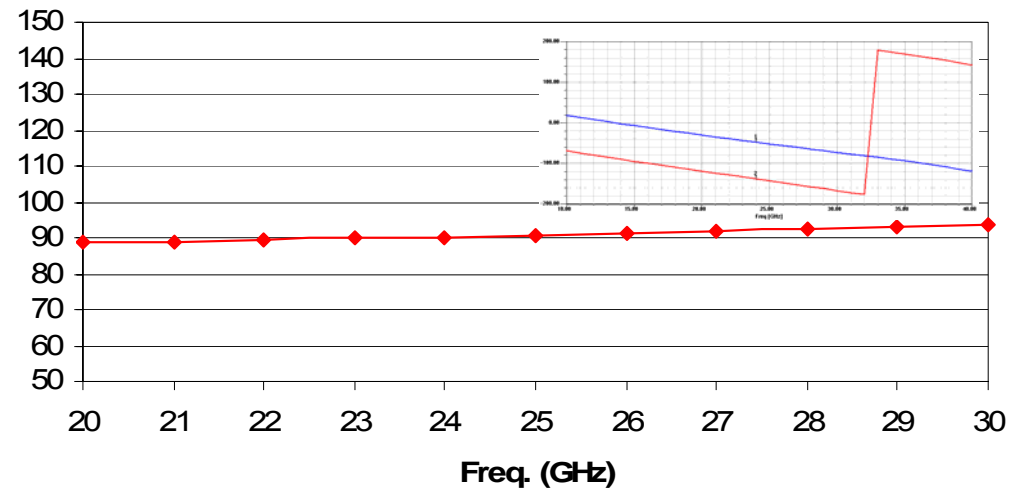

- Centre Frequency : 24GHz
- Direct Port : 3.63 dB ( — )
- Coupling Port : 3.67 dB ( — )
- Isolation : 18.9 dB ( — )
- Return Loss : <-20 dB ( — )
- Phase Division : 90.1° @ 24GHz

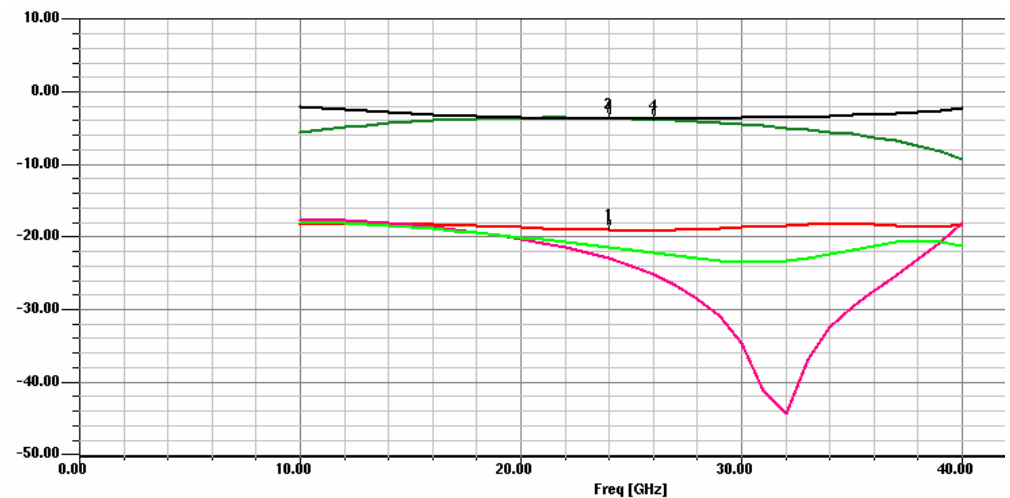

# Power Divider Design

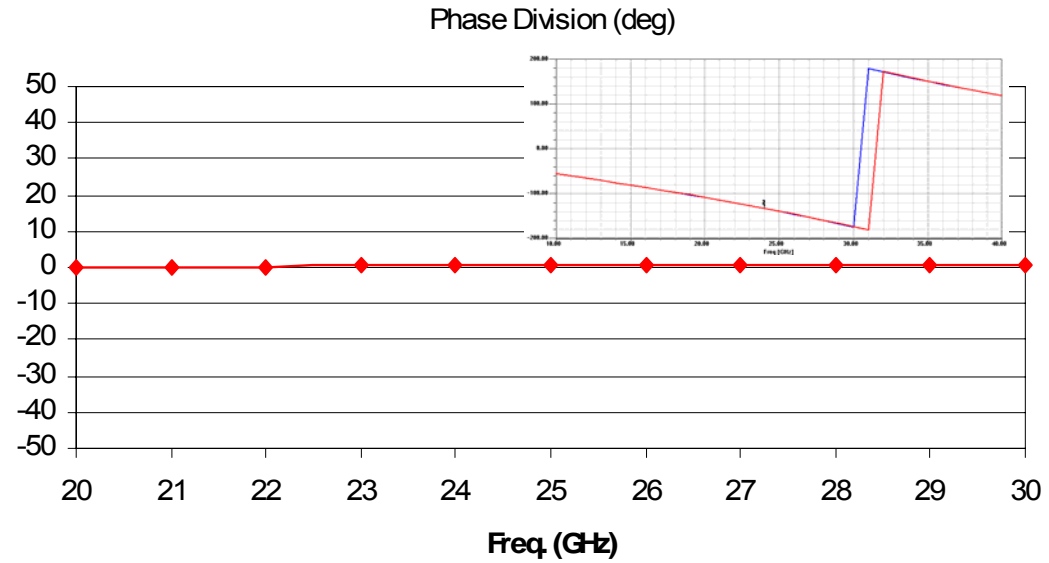
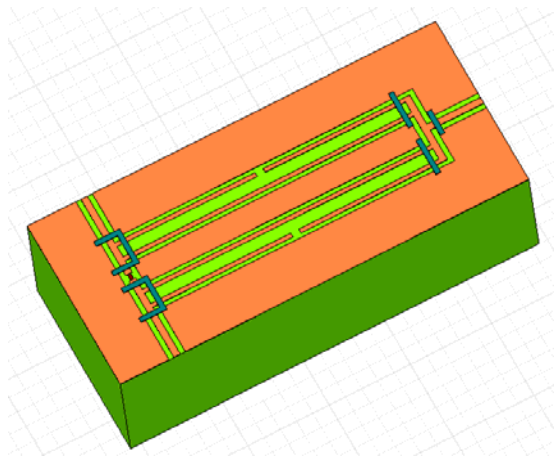

- Centre Frequency : 24GHz
- Power Division : 3.6dB ( — )
- Isolation : -22dB ( — )
- Return Loss : <-16dB ( — )
- Phase Division : <0.4°

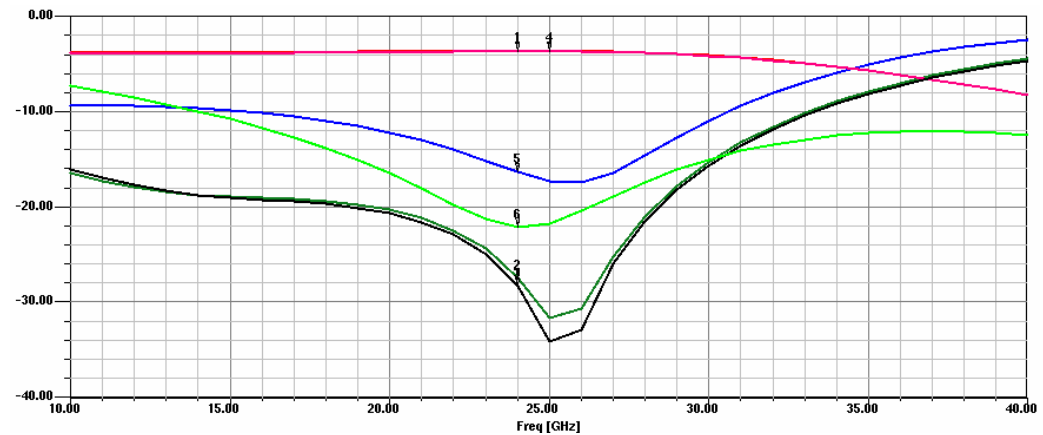

# IQ Mixer Design

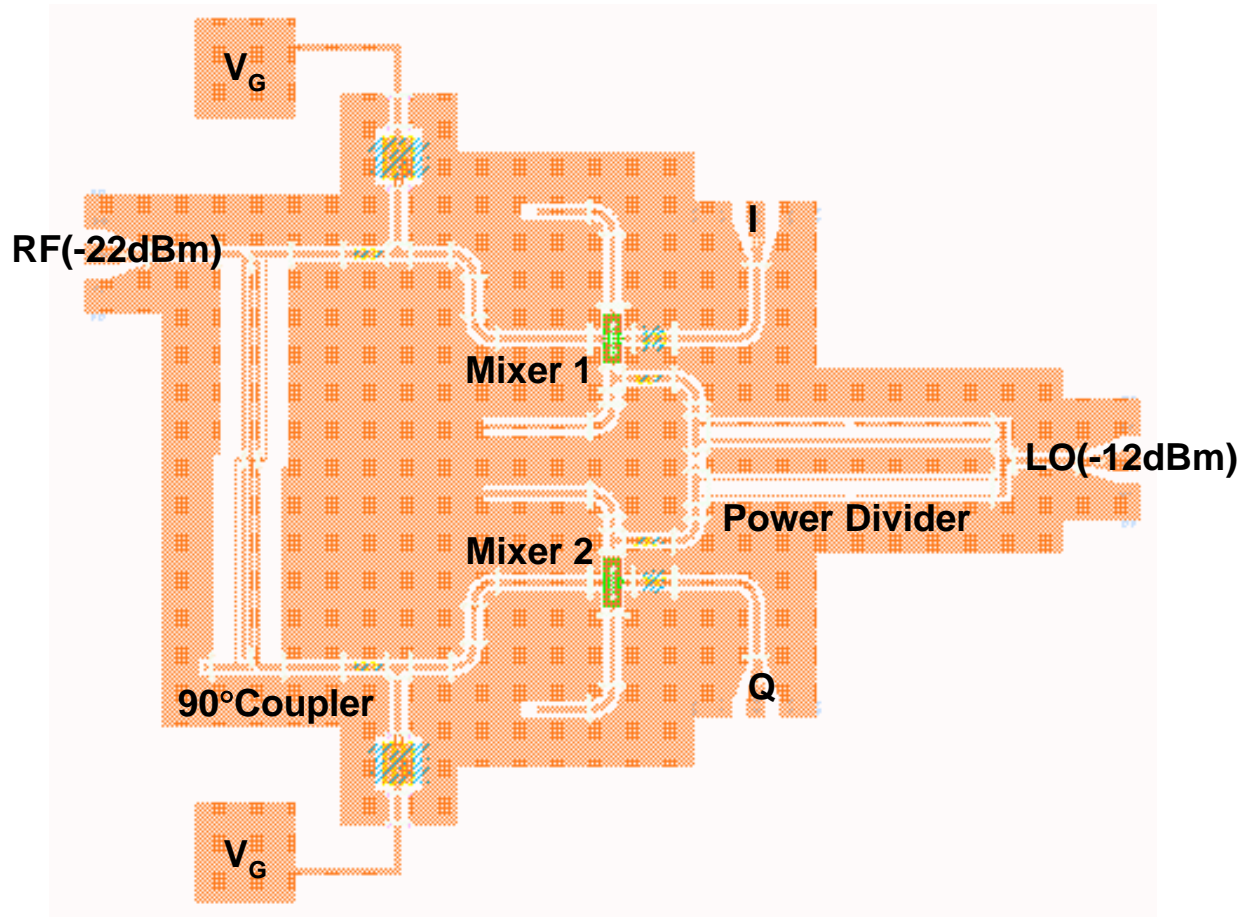

3.1 × 2.6 mm<sup>2</sup>

# IQ Mixer Design

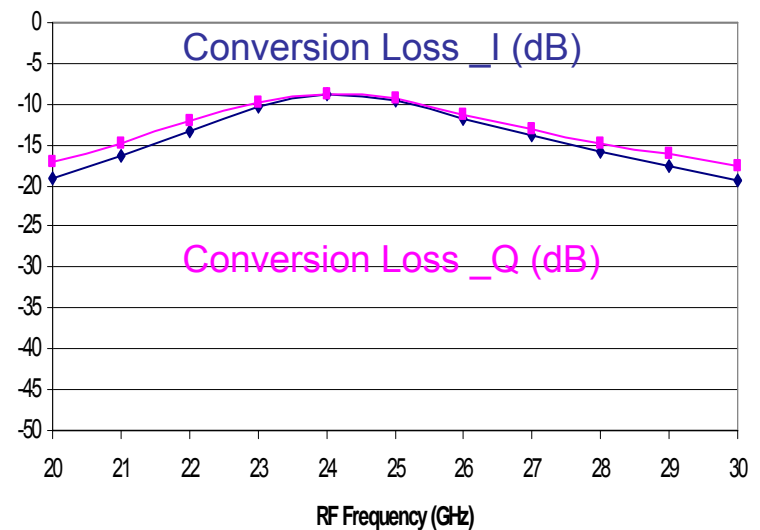
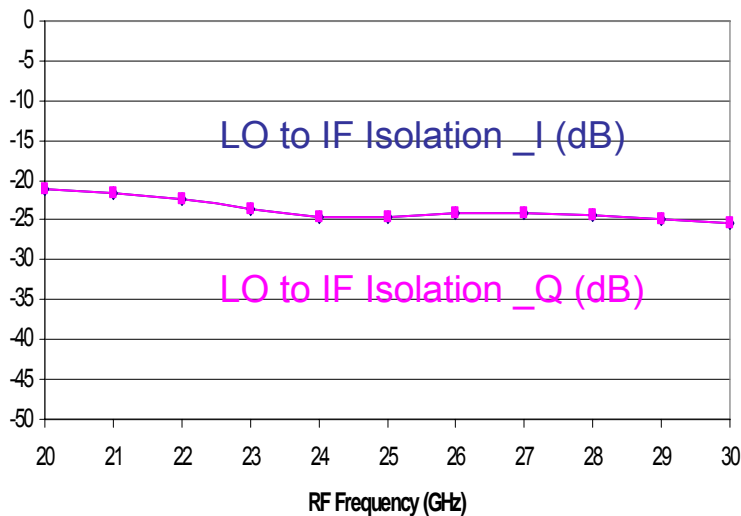
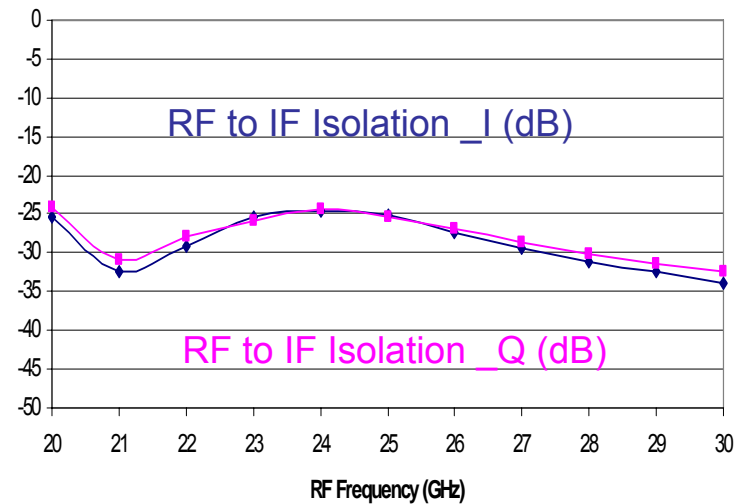
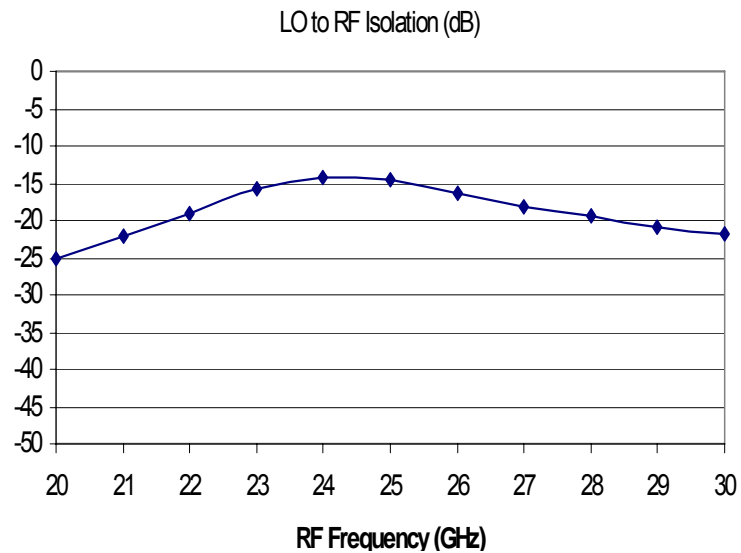

- 24GHz Direct Conversion Transceiver Architecture for UWB
- VCO Design for TX Power Source and LO
- Mixer Design (LO Source Injection) for Low Power Applications
- Passive Circuit Design for IQ Mixer Design
- IQ Mixer Design using Integration of Unit Mixer and Passive Circuit