

Miniaturisation of Antennas for Specknet

Griogair Whyte

Ultrafast Systems Group

Glasgow University

G.Whyte@elec.gla.ac.uk

Supervisor: Iain Thayne



Outline

- **How do you miniaturise?**
- **Miniaturisation trade offs.**
- **Current Work.**
- **Future Work/conclusions.**

How do you Miniaturise?

Dipole in free space.

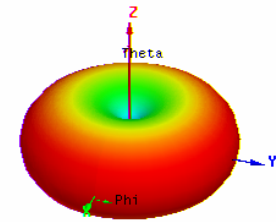
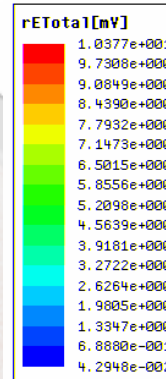
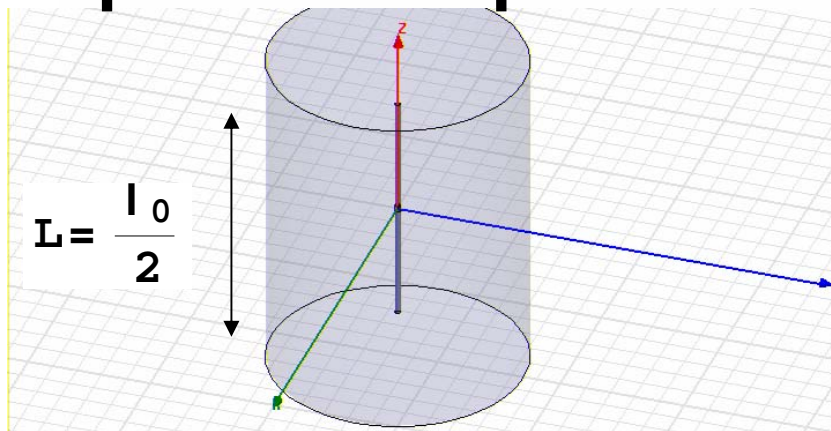

$L = 61.2\text{mm}$

$l_0 = 0.1224\text{ m}$

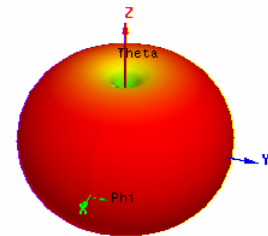
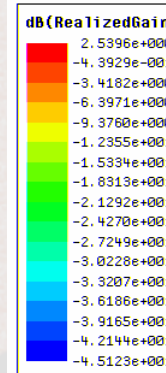

• Frequency = 2.45 GHz

• Permittivity (ϵ_r) = 1

• Effective wavelength = free space wavelength / sqrt effective permittivity

Increase Frequency and dielectric constant

- **Going from 2.45 GHz to 5.8 GHz results in a approx size reduction of two thirds.**
- **But propagation losses increase by 7 dB.**
- **Gain is approx same.**
- **Further reduction by increasing Dielectric Constant around antenna. ($1/\sqrt{\text{dielectric constant}}$)**

Miniaturisation trade offs

- **Reduced efficiency (Gain).**
- **Shorter range.**
- **Smaller useful bandwidth.**
- **Increased sensitivity to external factors.**
- **Hence more critical tuning.**

Proposed design – Helical Antenna

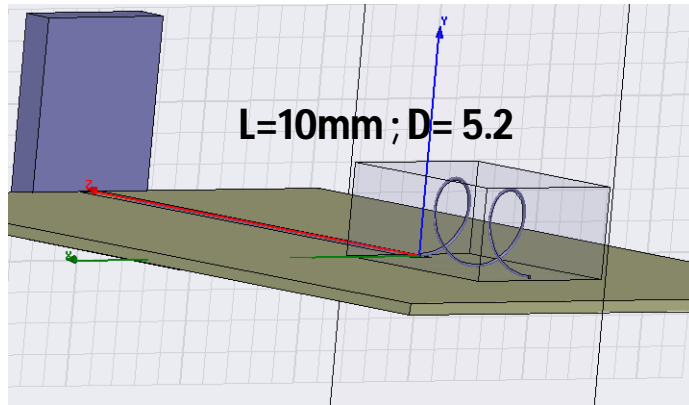

Two turn Helical Antenna @ 2.45 GHz on low perm substrate

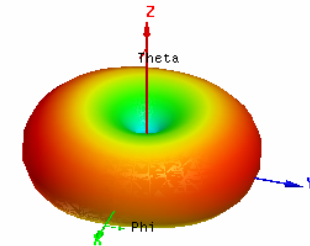
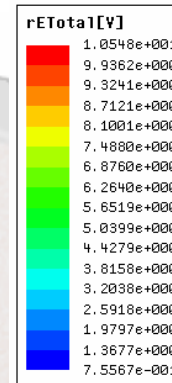

E-field Pattern

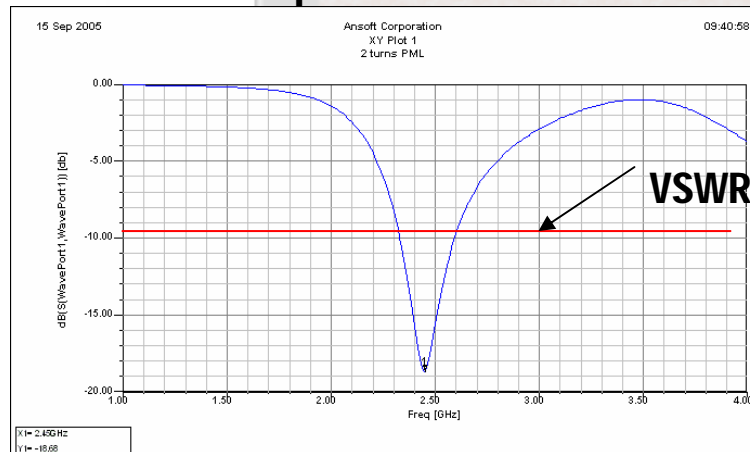

Return Loss = -18dB @ 2.45 GHz; BW = 260 MHz

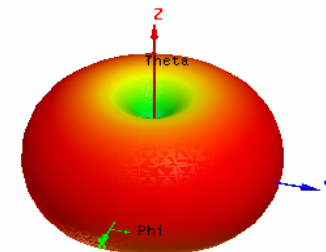
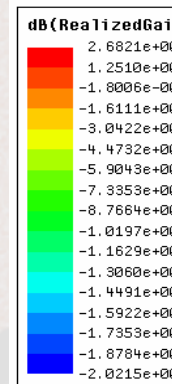

Gain Pattern

Helical Antenna

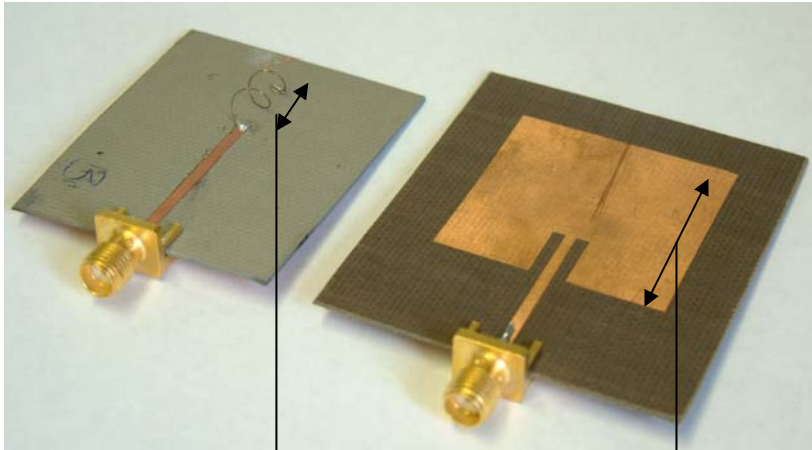

L=10mm; d=5.2

L=34mm²

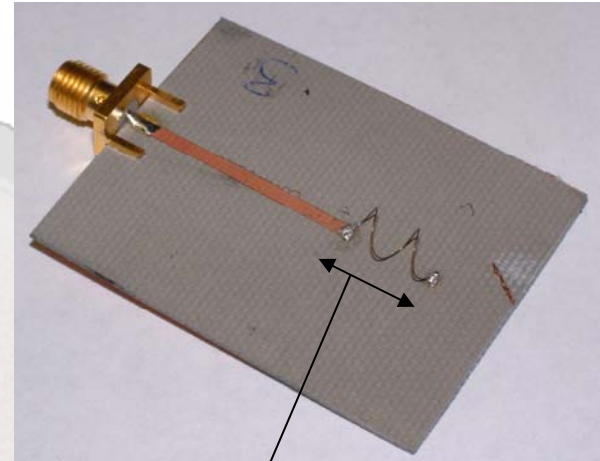

L=10mm; d=5.2

- Length can be less than a tenth of a wavelength at the operating frequency.
- Further reduced by increasing effective dielectric constant.

Initial experiments

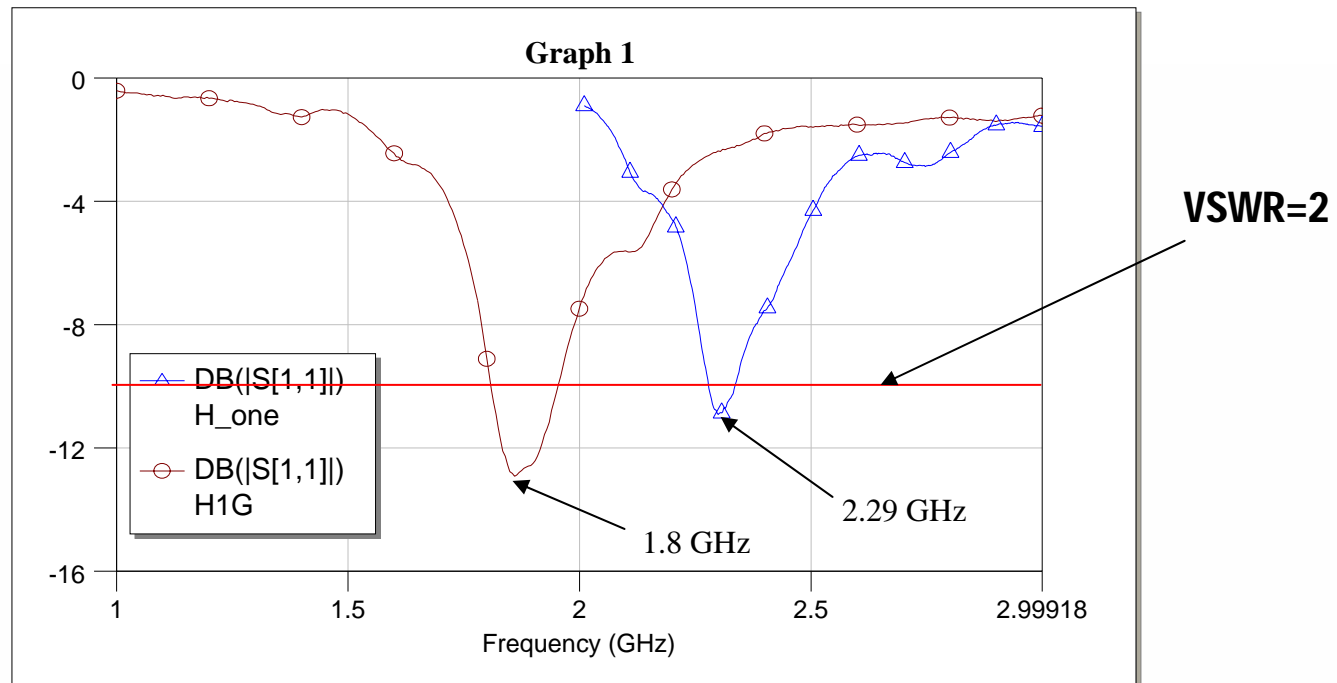

- Encasing antenna in epoxy (B&Q special).
- Mechanical strength.
- Increasing effective dielectric constant.
- Reduction in size of approx 1/3rd (L=6.6mm; d=3.8mm).
- May become impractical at higher frequencies.

Proposed design for 5 x 5 mm – Square Helix.

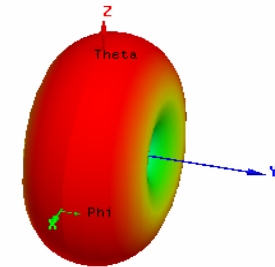
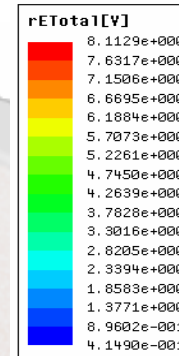
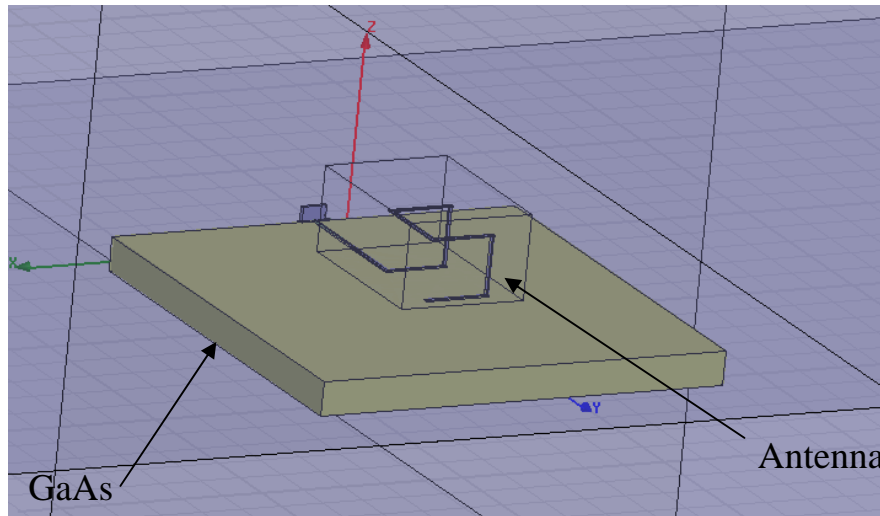

Total dimensions in this picture are:

GaAs substrate 5 x 5 x 0.4 mm.

Antenna in Silicon 2 x 1.2 x 1 mm.

Square Helix in Silicon or LTCC

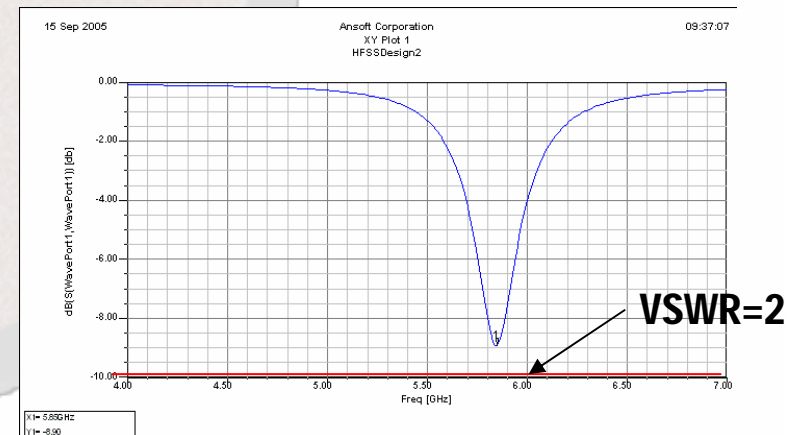

- Problems are matching to CPW feed and small GND.

Conclusions

- **Moving up in frequency (5.8 GHz at least).**
- **Higher permittivity materials.**
- **What will the layout and configuration of the Speck be?**
- **LTCC or Silicon square Helix.**

Miniaturisation of Antennas for Specknet

Griogair Whyte

Ultrafast Systems Group

Glasgow University

G.Whyte@elec.gla.ac.uk

Supervisor: Iain Thayne

