

Receiver Synchronisation for CDMA Based SpeckNet Optical Communications

Louise Crockett

University of Strathclyde

louise.crockett@eee.strath.ac.uk



Summary

- Problem: localisation using optics
- Code Division Multiple Access (CDMA)
- Receiver timing synchronisation
 - Generic symbol synchronisation
 - CDMA-specific
- Challenges for CDMA free space optics

Localisation Using Optics

- Free space optics can potentially generate directional information for localisation. However...
 - Sources must be distinguishable from each other.
 - Several sources per Speck... which allows its different faces to be identified.
 - Specks should be as heterogeneous as possible.

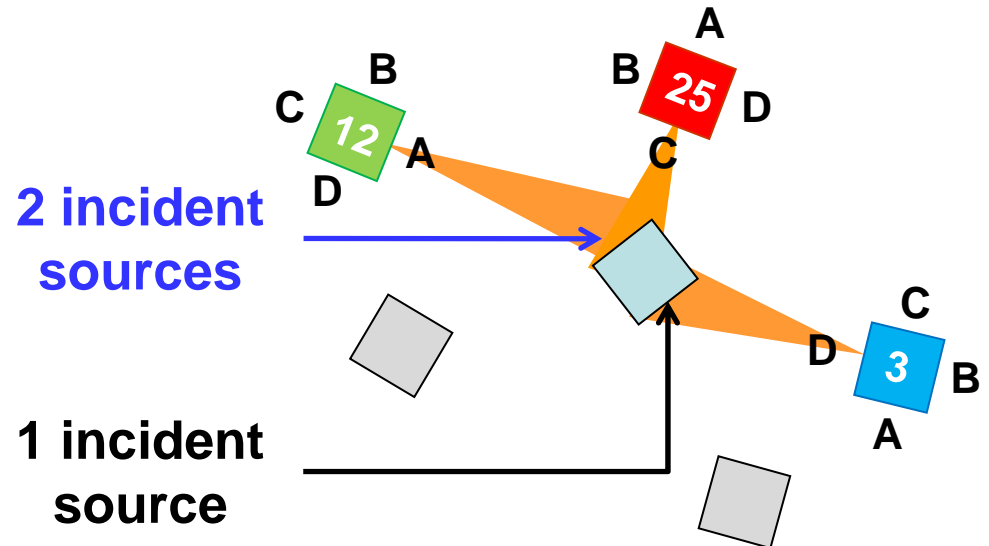
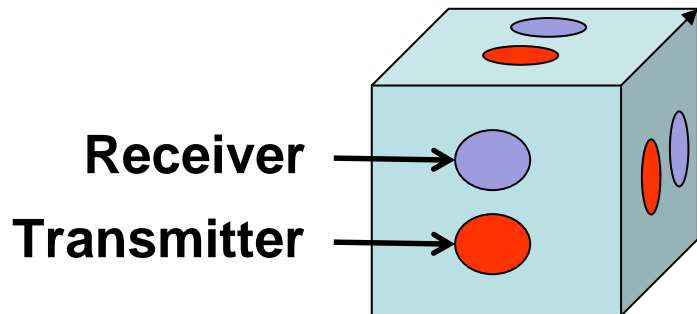

Separating Sources

- Assuming that optical sources are “identical”, they still need to be distinguishable in some way.
- Code Division Multiple Access is extensively used in wireless communications...
 - Sources share same frequency.
 - Orthogonal or near orthogonal codes are used to make them distinct. Each symbol is conveyed by G chips, where G is the code length.
 - Several families of CDMA codes exist... Gold codes have been chosen for this investigation.
 - Codes comprise several “chips” which are either +1 or -1.
 - Sources are separated at the receiver by correlating with the expected CDMA code(s).

Example Gold Code

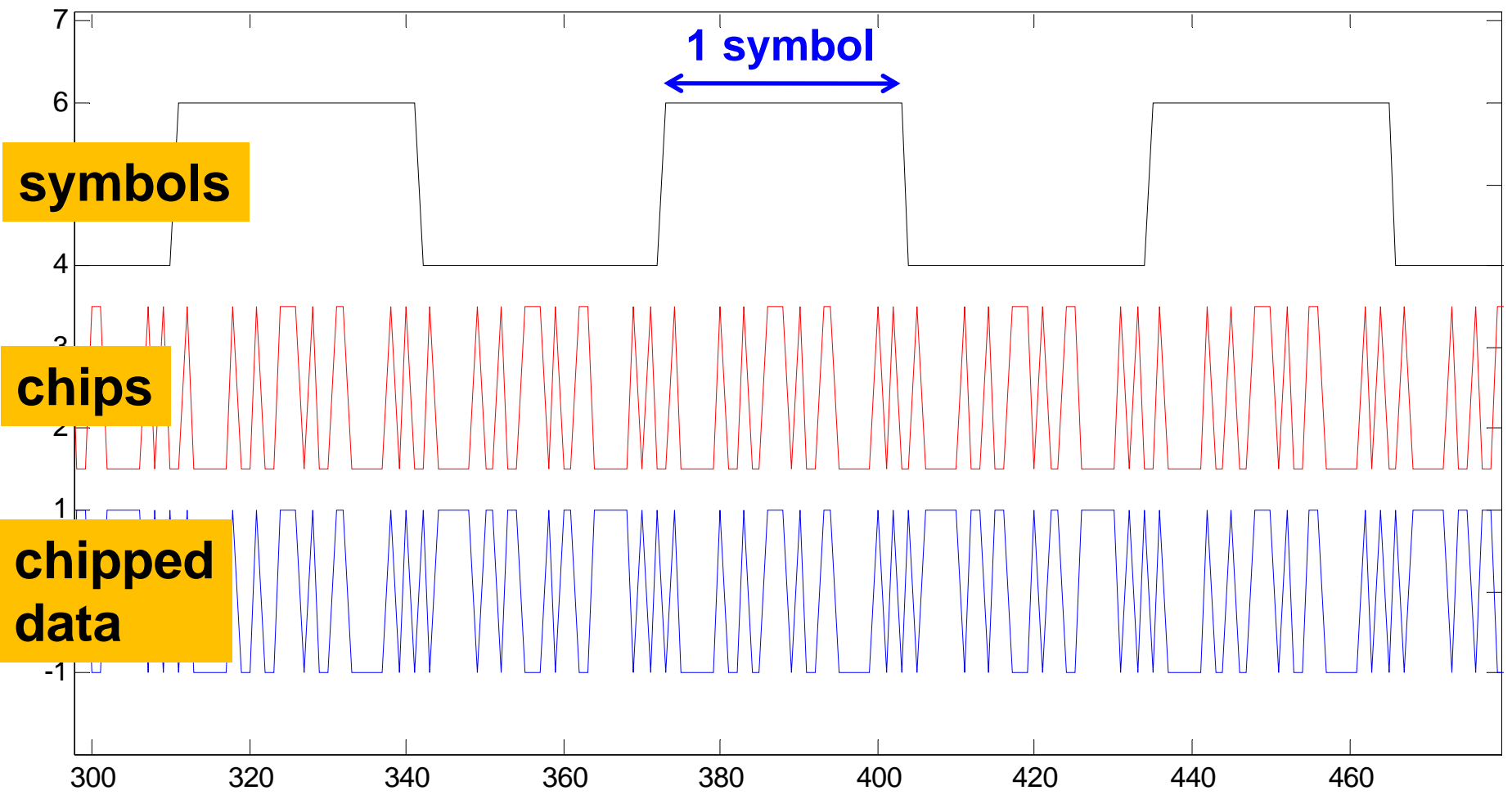

Superposition of Gold Coded Sources

**4 sources
(equal
power)**

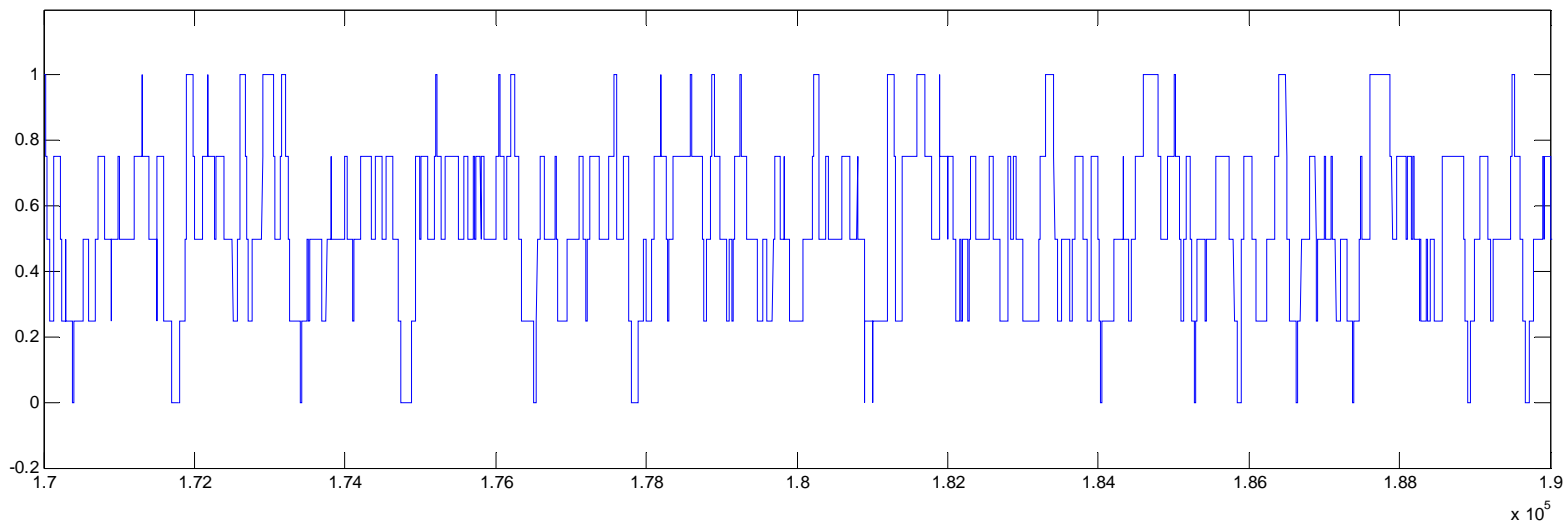

**6 sources
(unequal
power)**

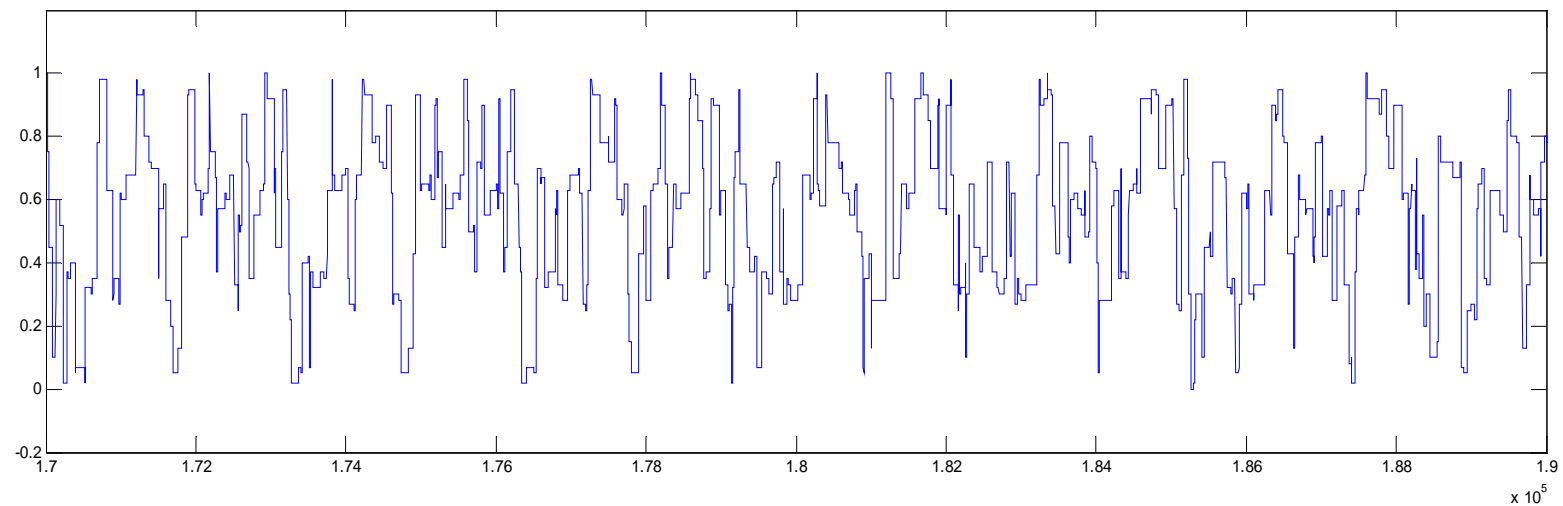

Ideal CDMA Detection

- If the received code is applied to a matched filter* with the correct code, a correlation peak is observed every symbol period... even if other sources are present.

* The matched filter coefficients are the spreading code, backwards.

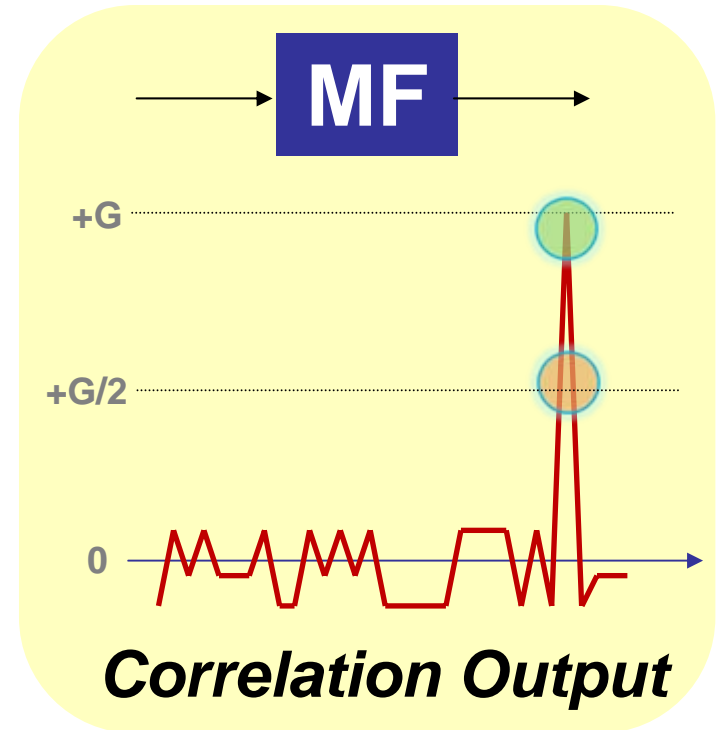

- Optics offers only +1/0 chips (unipolar).
- The amplitude of the correlation peak is reduced by $\frac{1}{2}$ compared to the bipolar (+1/-1) case.

Matched Filter Correlator Output

Unipolar

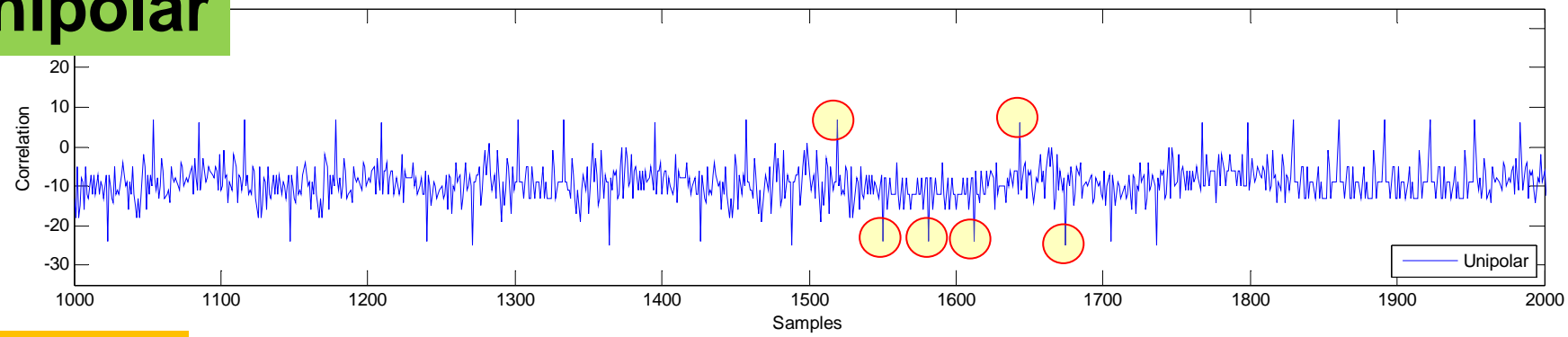

Bipolar

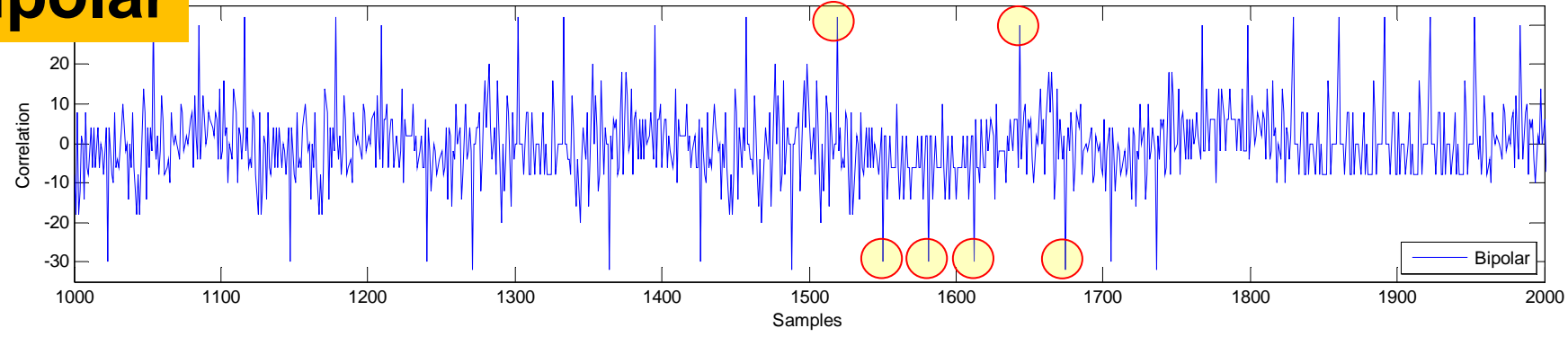

1 equal power interferer present

Non-ideal Detection!

- If the transmitter and receiver were synchronised in time, CDMA reception would be (relatively!) straightforward.
- However in a realistic scenario, the clocks in the communicating Specks are different, and the receiver must synchronise to the received signal.
- There is almost certainly:
 - A phase offset, and
 - A frequency offset.

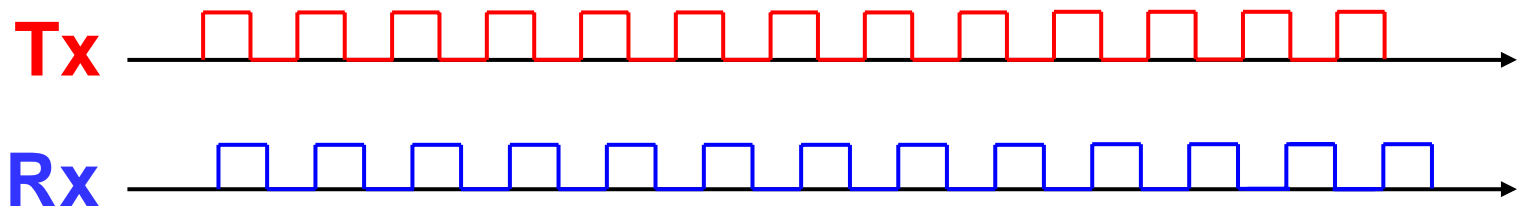

Problems...

- We now have the compounded problem of retrieving a signal buried in noise and interference, with unknown timing parameters.
- Simply matched filtering with the code will not suffice.
 - The receiver is clocked at a different rate than the received signal.
- Timing synchronisation is necessary.

Timing Synch Review 1: Max. Effect Points

- First of all we matched filter the received signal with the expected pulse shape... this helps to reduce noise and find the **Maximum Effect Points (MEPs)**.

Transmitted Signal

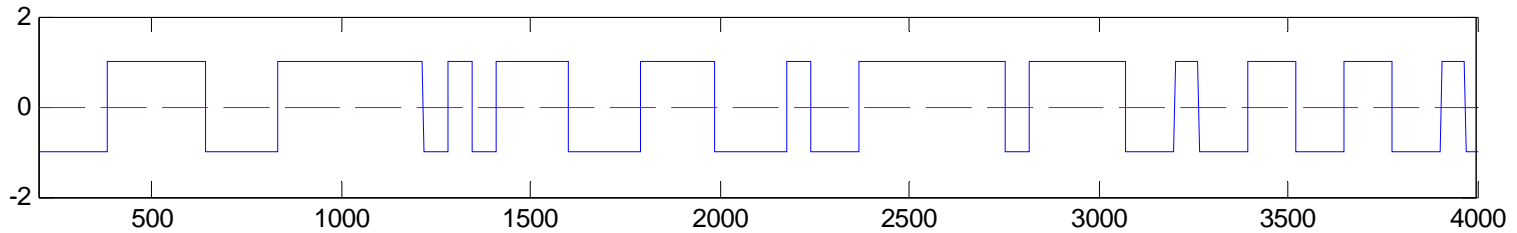

Received Signal

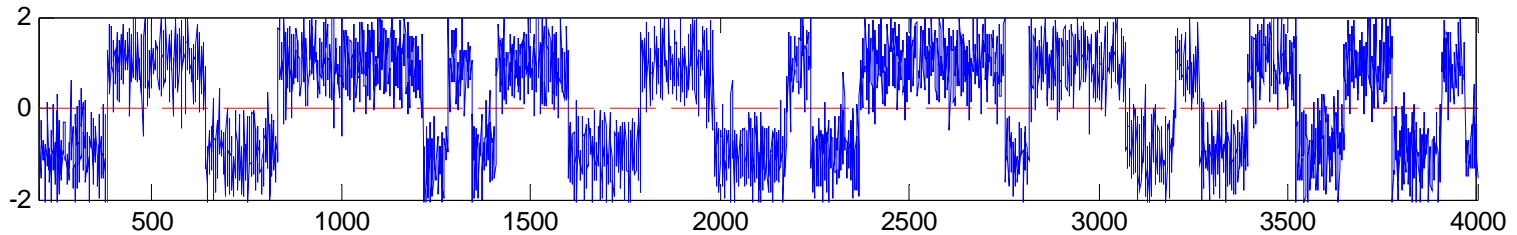

Received Signal after Matched Filtering

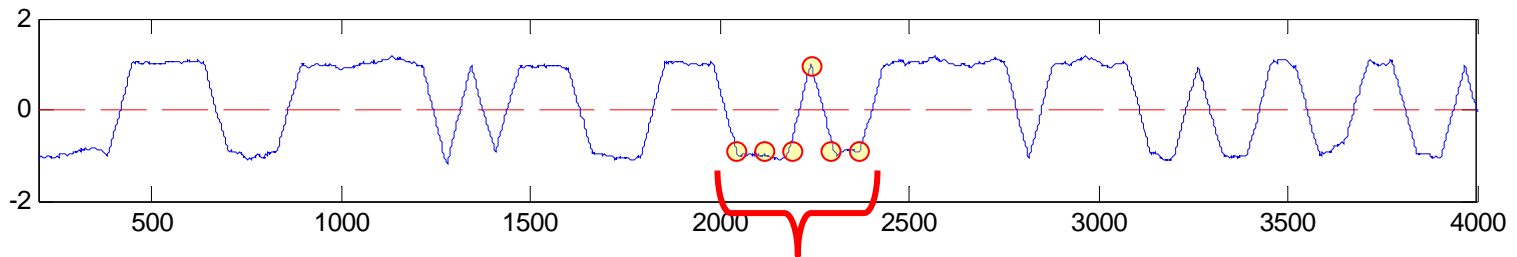

Examples of Maximum Effect Points

Timing Synch Review 2: Early / Punctual / Late

- After matched filtering, the synchroniser's task is to sample at the MEPs.
- One popular method is the Early Late Gate.
 - The **P**unctual samples are located at the MEPs, with the aid of the **E**arly and **L**ate samples.
 - The degree of timing adjustment depends on the negative of the gradient.

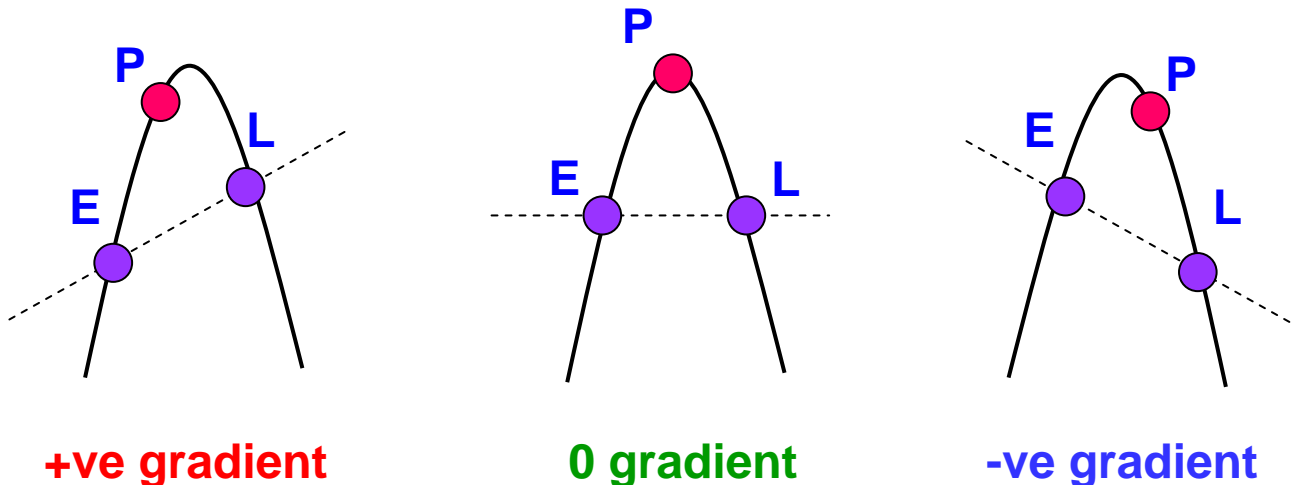

Timing Synch Review 3: Early Late Architecture

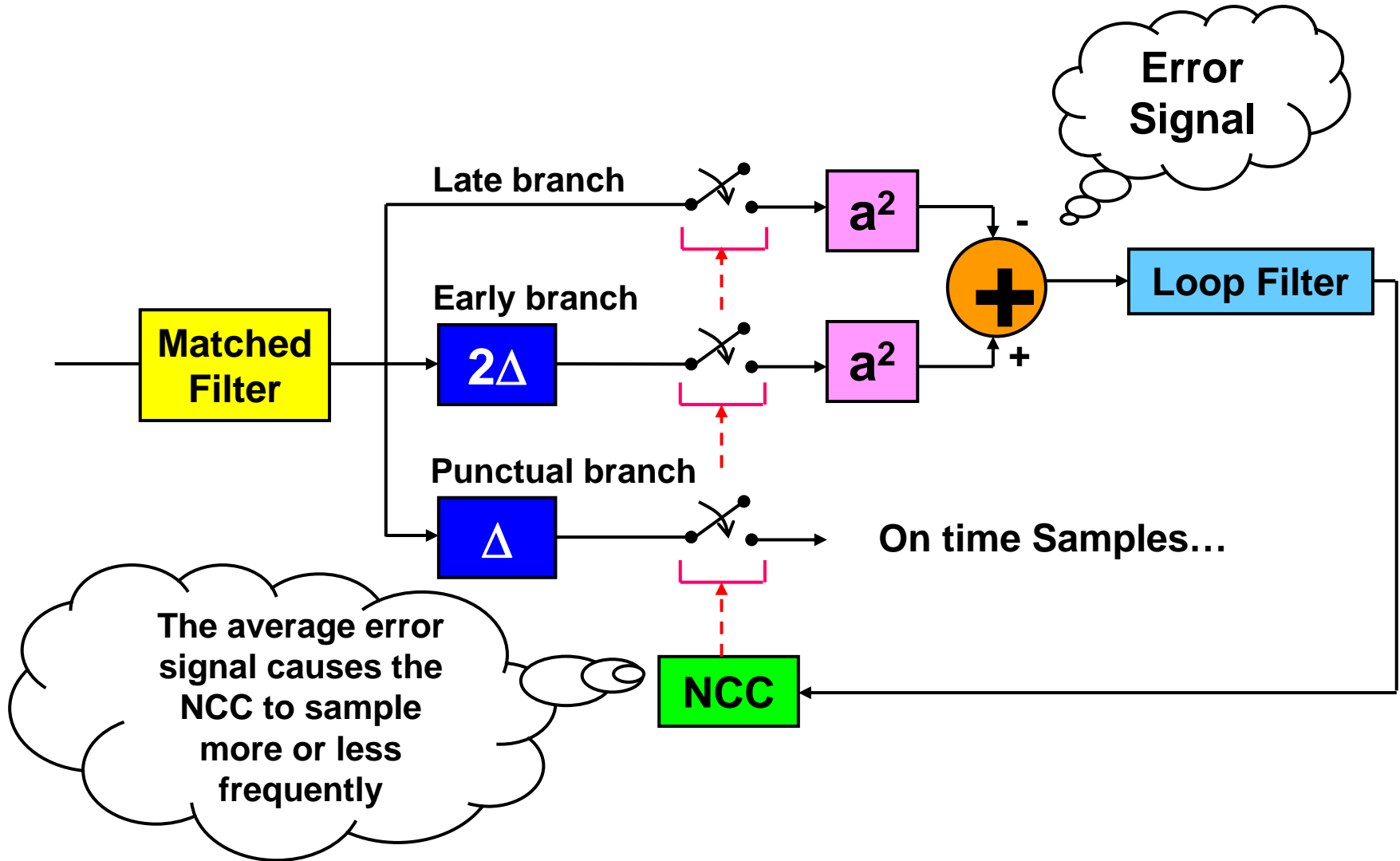

Symbol Timing Synchronisation

**Received
Signal**

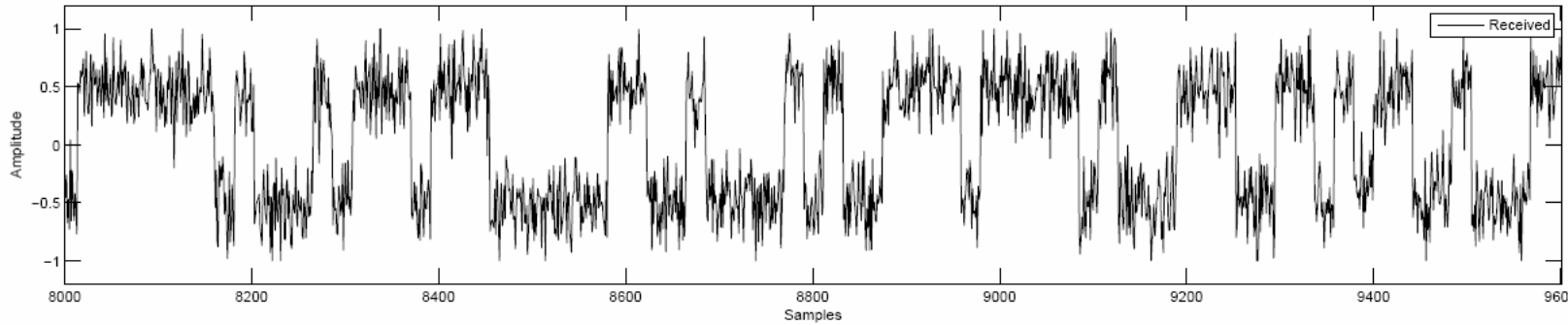

**Synch.
Process**

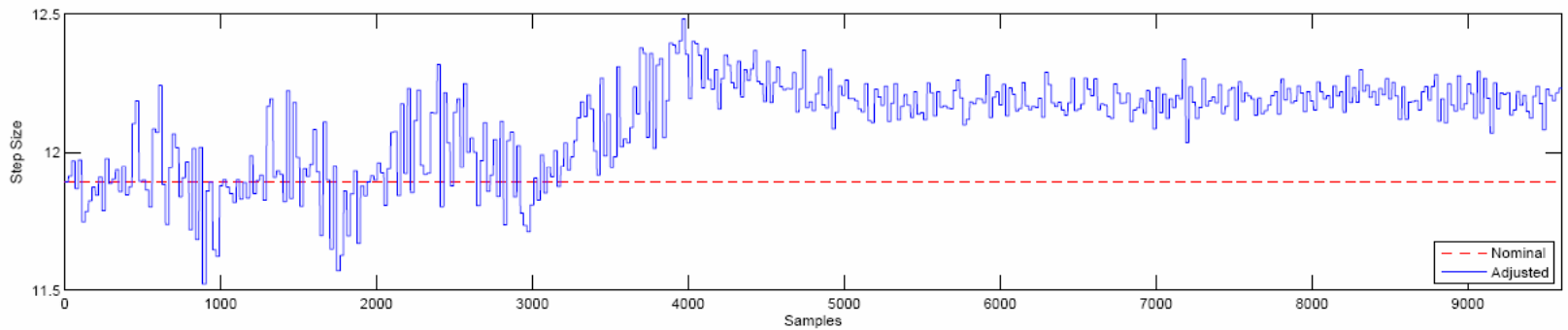

**Symbol
Sampling
After
Synch.**

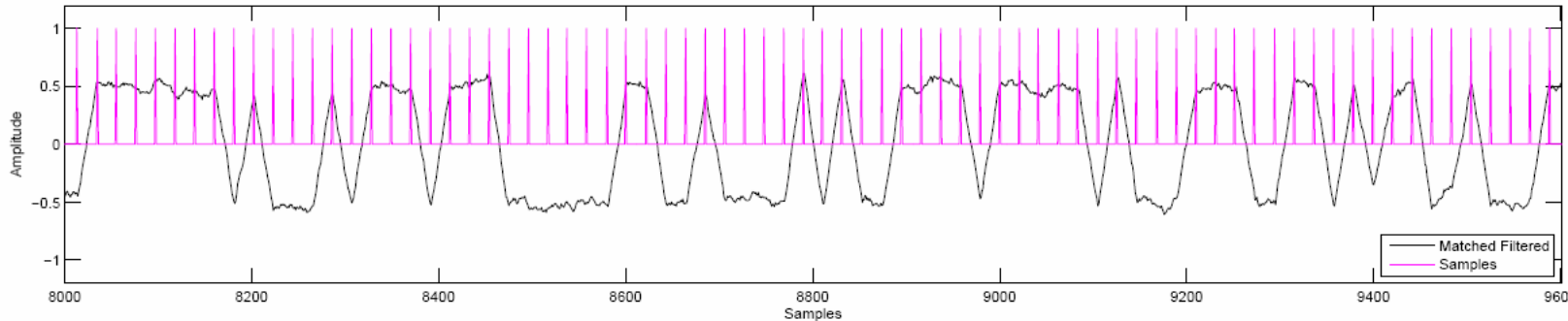

(CDMA) Spread Spectrum Synchronisation

- Firstly, note that when spreading codes come into alignment, their average correlation tends towards ± 1 (± 0.5 with unipolar codes).

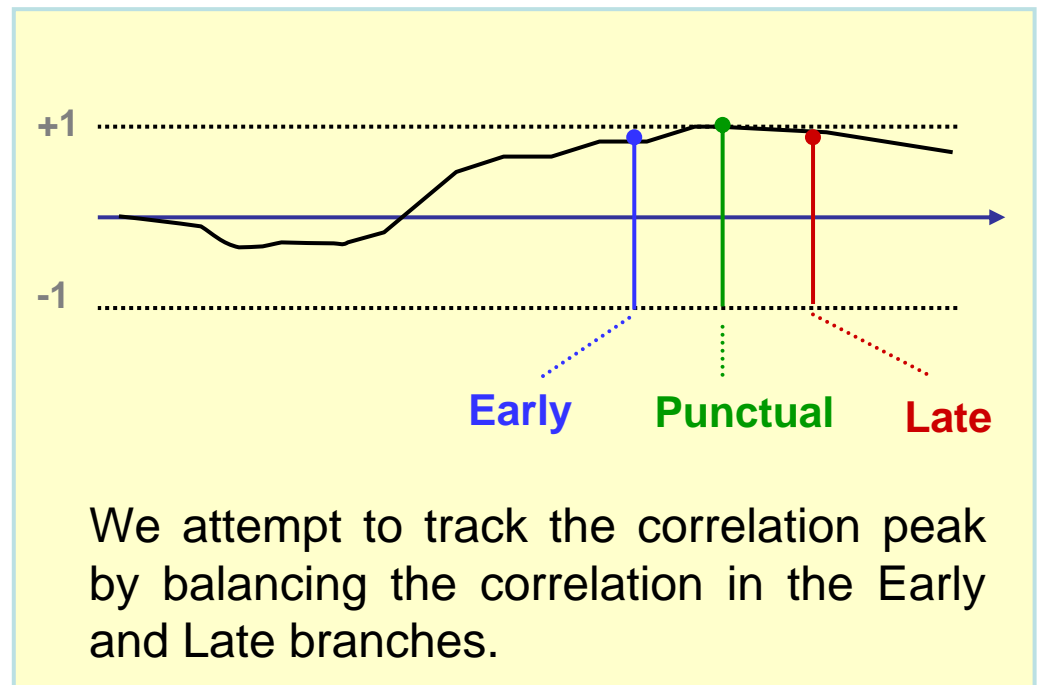
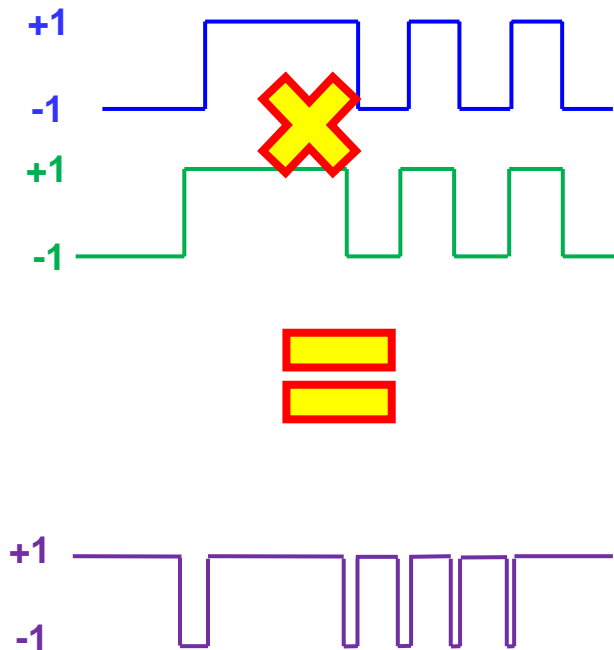

Spread Spectrum Synchronisation

- The spread spectrum synchroniser operates in three phases:
 1. **Acquisition** (i.e. coarse alignment – finding a peak)
 2. **Verification** (ensuring that it is a true correlation peak)
 3. **Tracking** (maintaining timing synchronisation by making fine adjustments).
- This synchroniser is much more complex than the non-spread timing synchroniser.
- Synchronisation “mistakes” can occur.
- Sensitive to the interference environment.

Spread Spectrum Early-Late

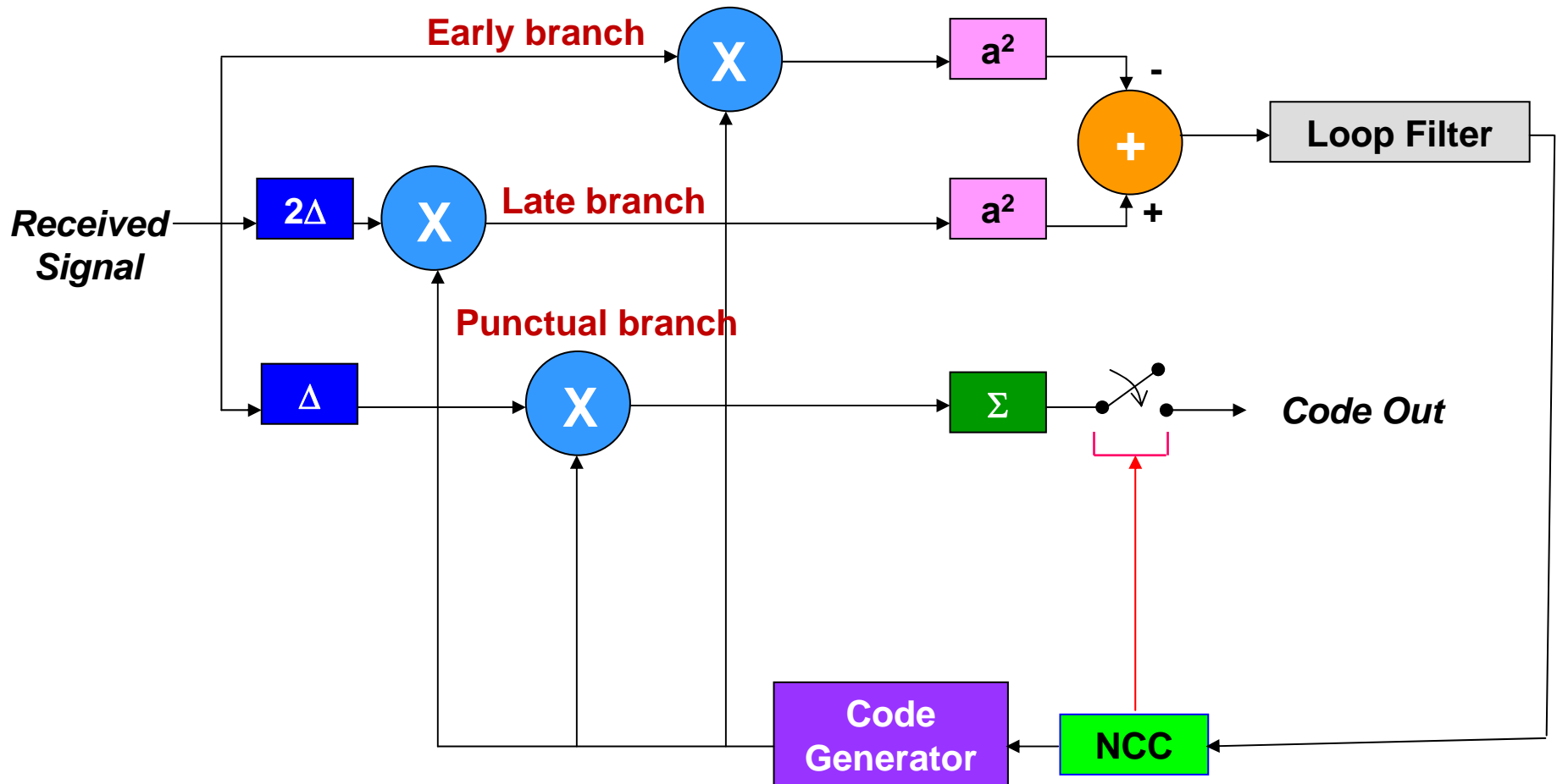

Simulation Results

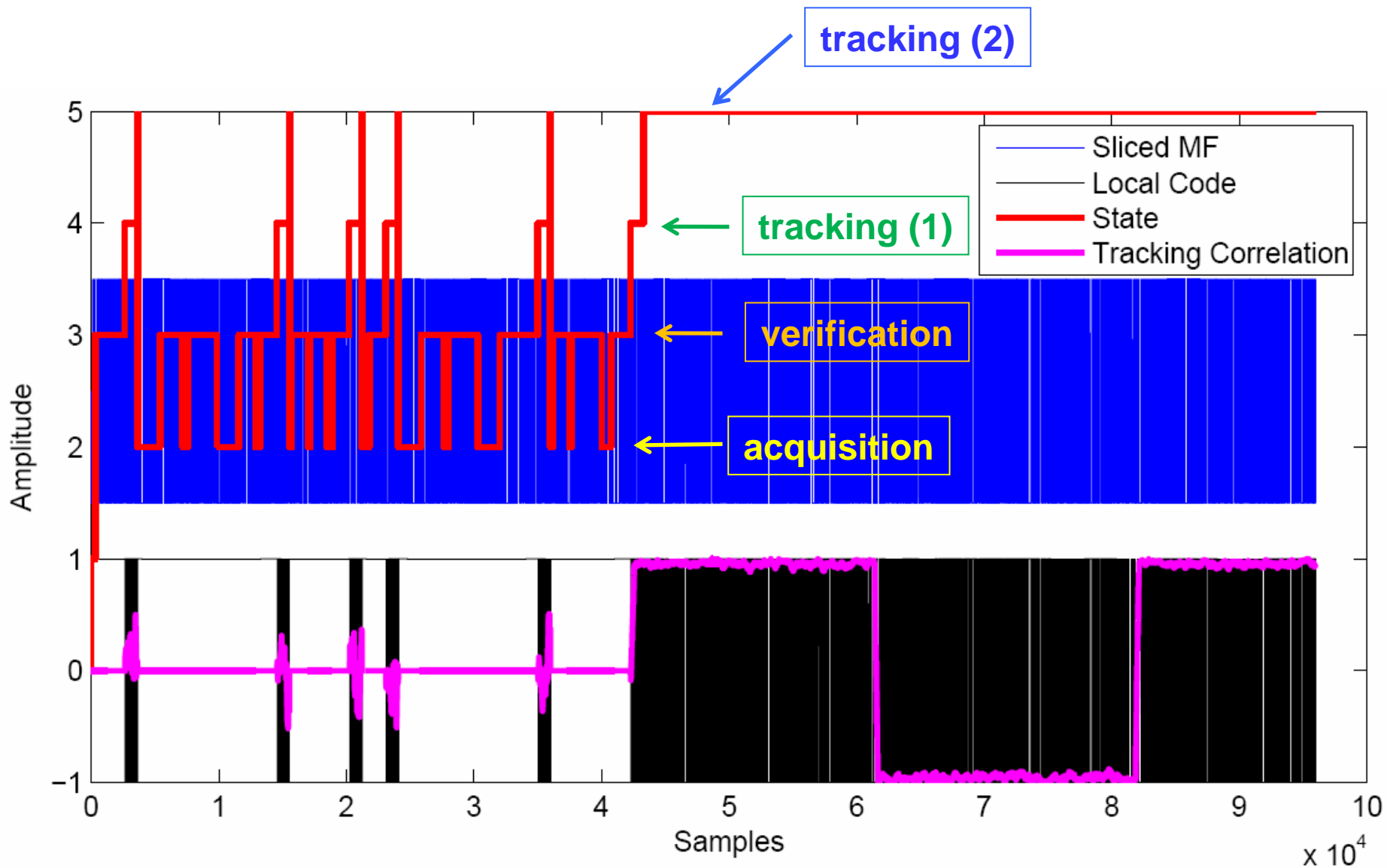

Further Work...

- More testing... particularly to check operation in interference and noise.
- Parameterisation of design.
- Integration with optical components.
- “Best Effort” approach to the Near Far problem?
- Optimisation of components...
 - If fixed point wordlength is reduced, how well does the synchroniser perform?
 - For SpeckNet, achieving a cheap and efficient implementation is important.

Review and Conclusions

- A method of aiding localisation using CDMA and free space optics has been conceived.
 - -1 chips cannot be used in optics (unlike radio).
- Various synchronisers and subsystems have been developed which are also applicable to radio communication.
 - A custom Speck radio will require synchronisation too!
- Progress has been made towards an FPGA prototype for integration with optics.
- Further work required to...
 - Make it work reliably
 - Achieve a “low” cost, efficient design