



Research Consortium in Speckled Computing

# OFDMA Synchronisation for Multichannel Data Extraction from Specknets

Neil MacEwen  
University of Strathclyde

[neil.macewen@eee.strath.ac.uk](mailto:neil.macewen@eee.strath.ac.uk)



# Outline

- Data extraction scenario with update rate and latency constraints
- OFDMA-based data extraction protocol
- Synchronisation requirements
- Subcarrier synthesis and frequency compensation

# Data extraction

- Situations where it is useful to extract data as efficiently as possible
  - Embedded Specknet with a stationary or mobile sink
- Wireless motion tracking
  - Data from motion tracking sensors collated at a single point

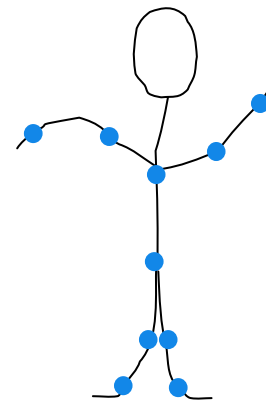
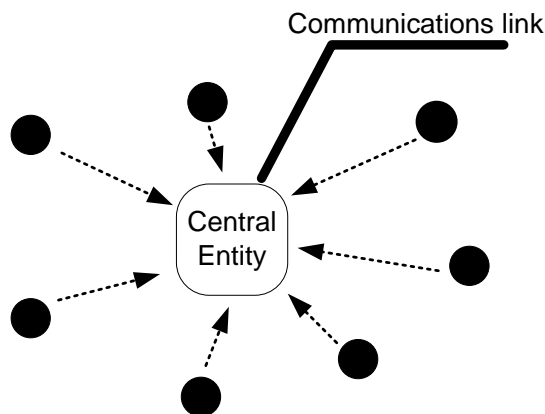

# Single hop data extraction

- Extract data in a single hop to a central location
  - Enables the simplest possible nodes
    - Simple transceiver
    - Minimise communication costs – no multiple hops
  - Is beneficial when there are update rate and latency requirements
    - e.g. the number of users is limited by single channel

# Update rate per user

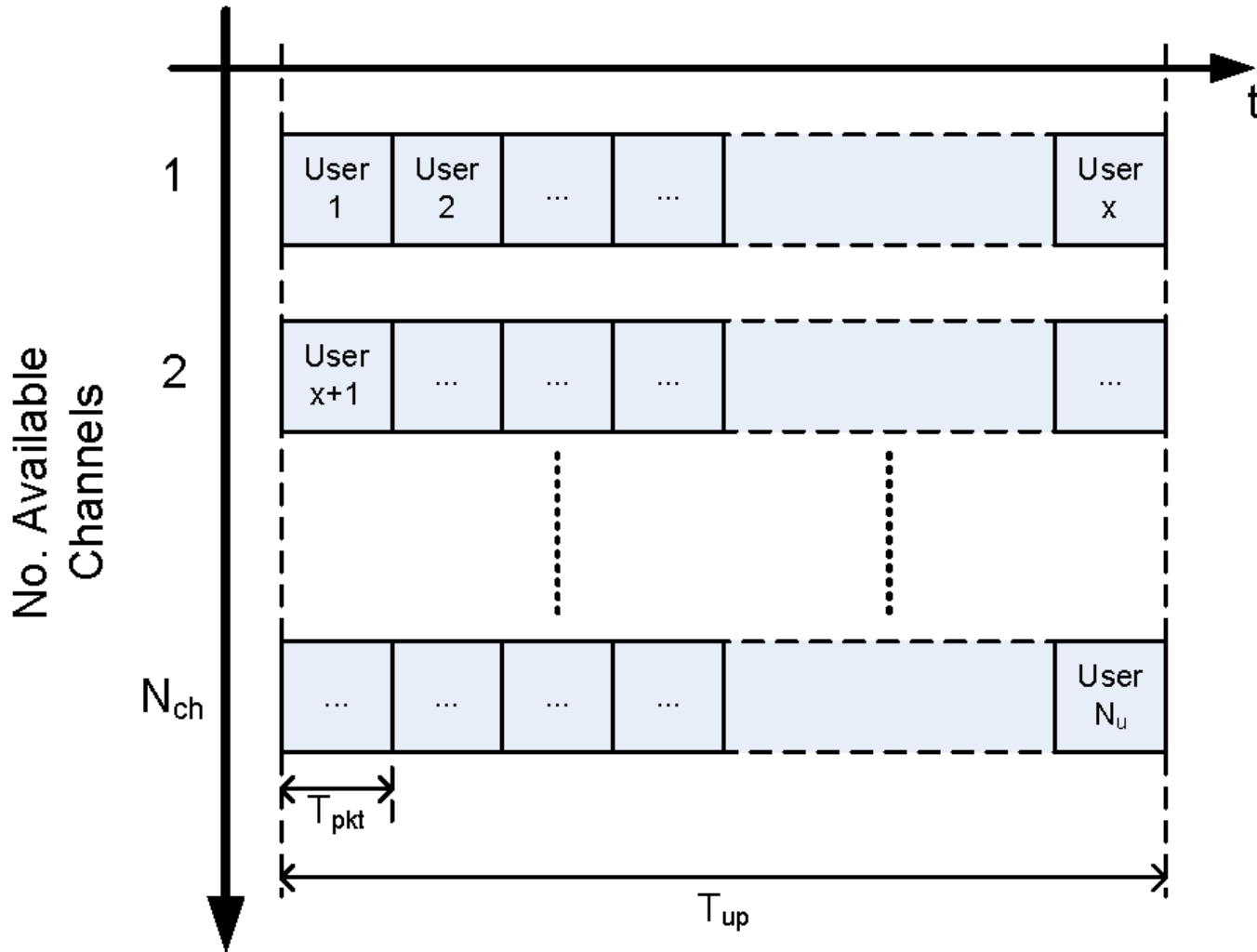

$$R_{up} = \frac{N_{ch}}{N_u T_{pkt}}$$

# Update rate per user, single channel

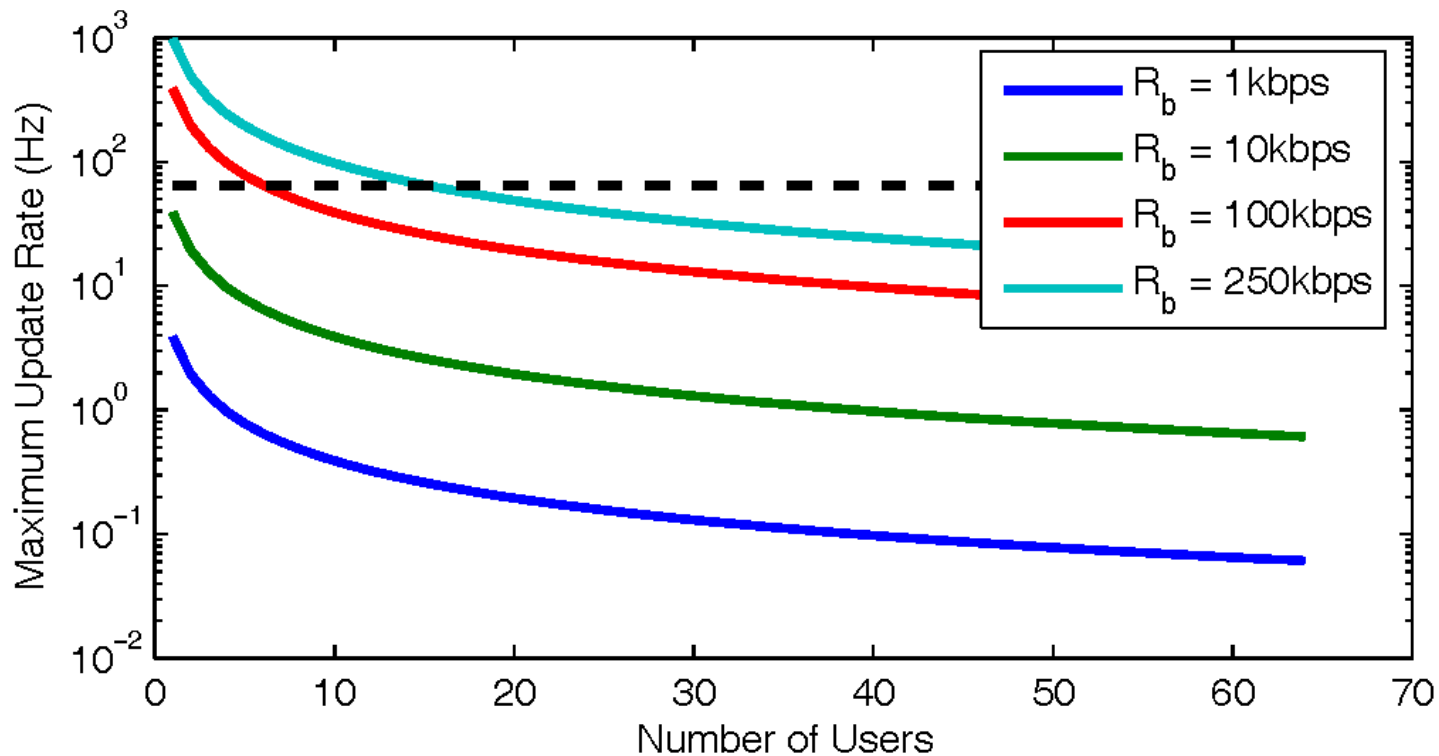

- Dotted line shows Orient-2 update rate of 64Hz
- Packet length 256 bits

# Implementing multiple channels, OFDMA

- Orthogonal Frequency Division Multiplexing (OFDM)
- Relatively simple DSP used to modulate data onto multiple carriers
- Main advantage is resilience to fading
  - Fading introduced by multipath effect, movement
- Multiple access by assigning different subcarriers

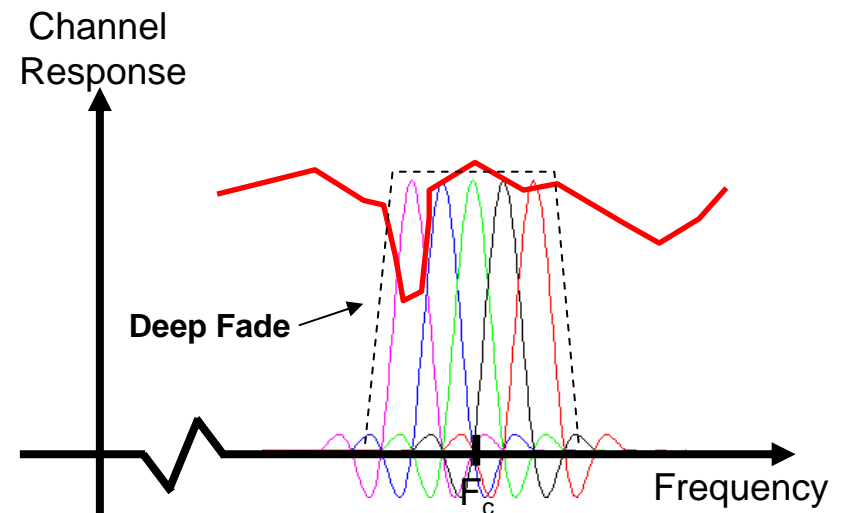
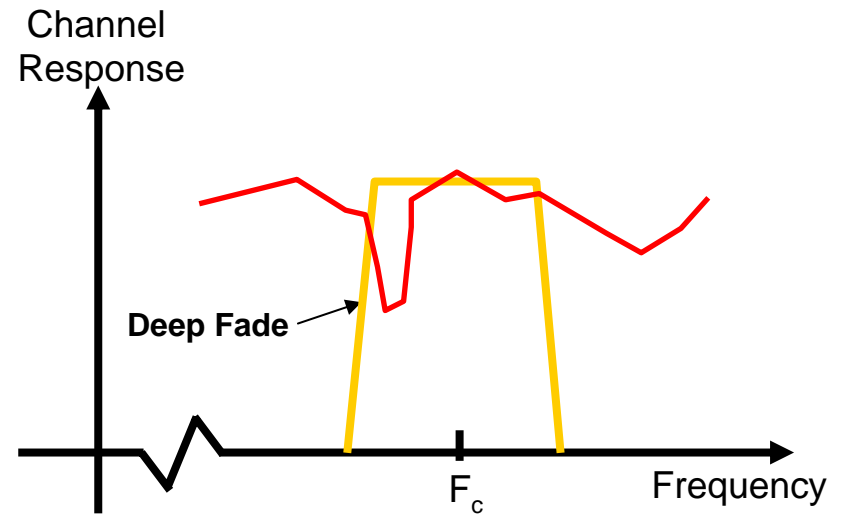

# Synchronisation problems

- Time offsets (arrival times)
  - Form a *quasi-synchronous* system
  - Offsets relative to propagation delays
  - Only effect of offsets (using cyclic prefix) is phase rotation – DQPSK
  - Keep offsets small, minimise redundancy needed for cyclic prefix
- Frequency offsets (Doppler and carrier offsets)

# Spectral effect of offsets

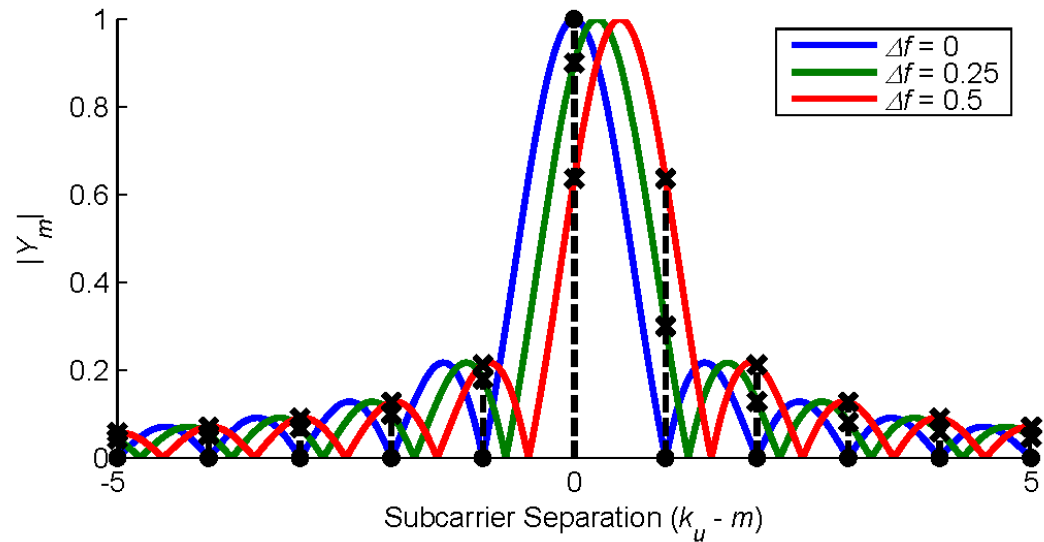
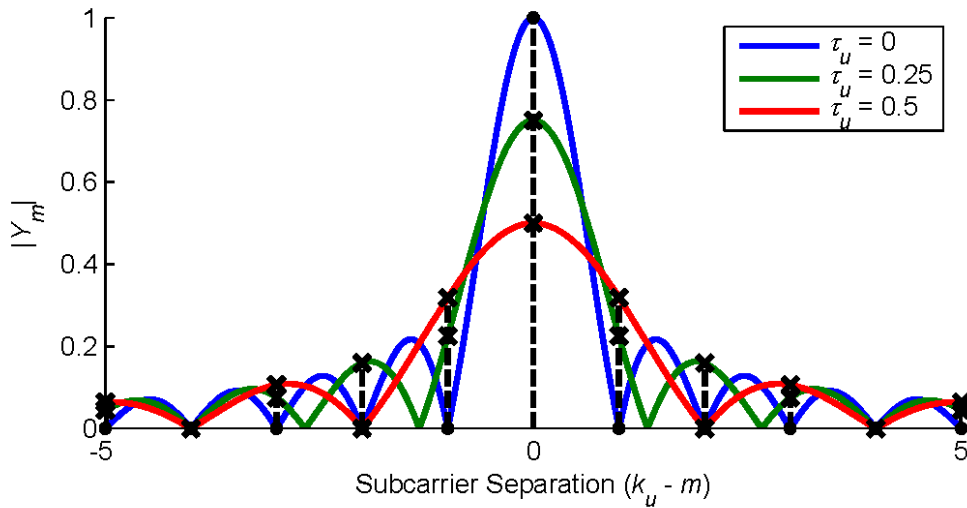

# BER degradation

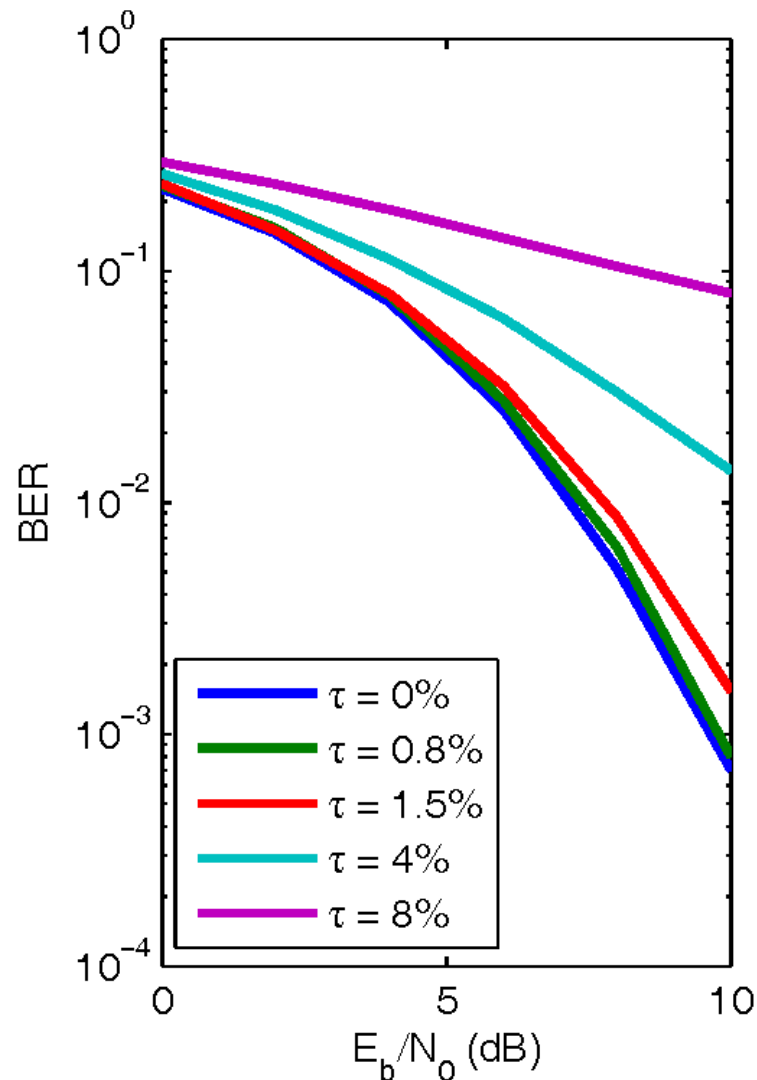
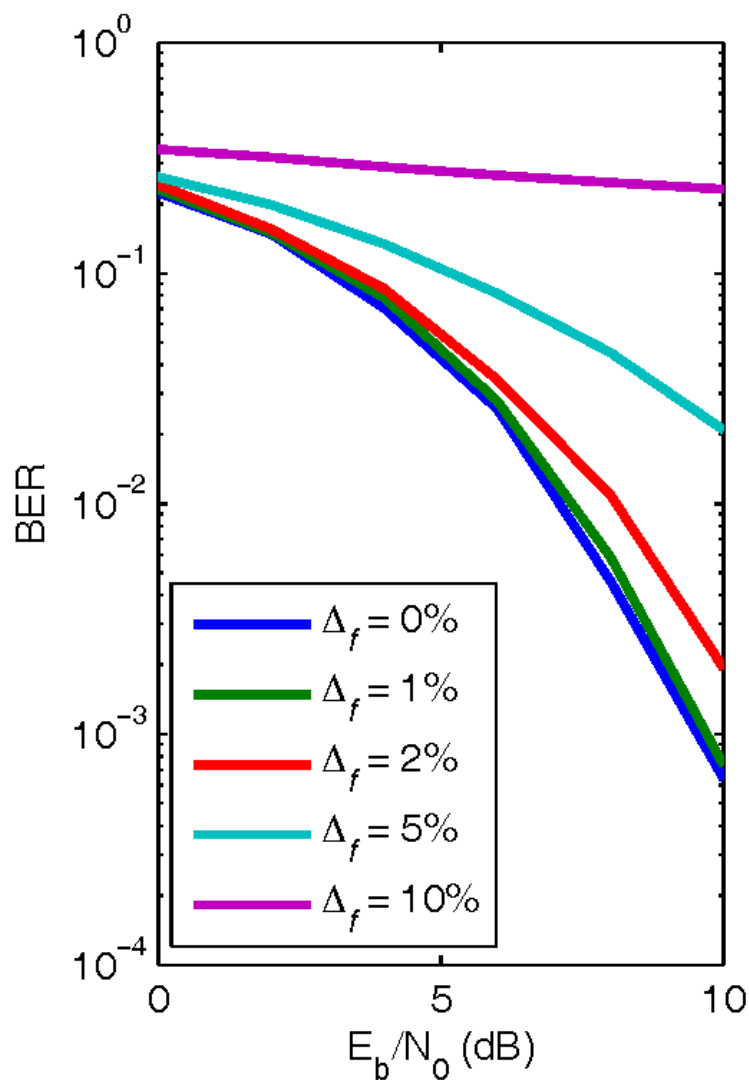

# Receiver initiated data extraction protocol

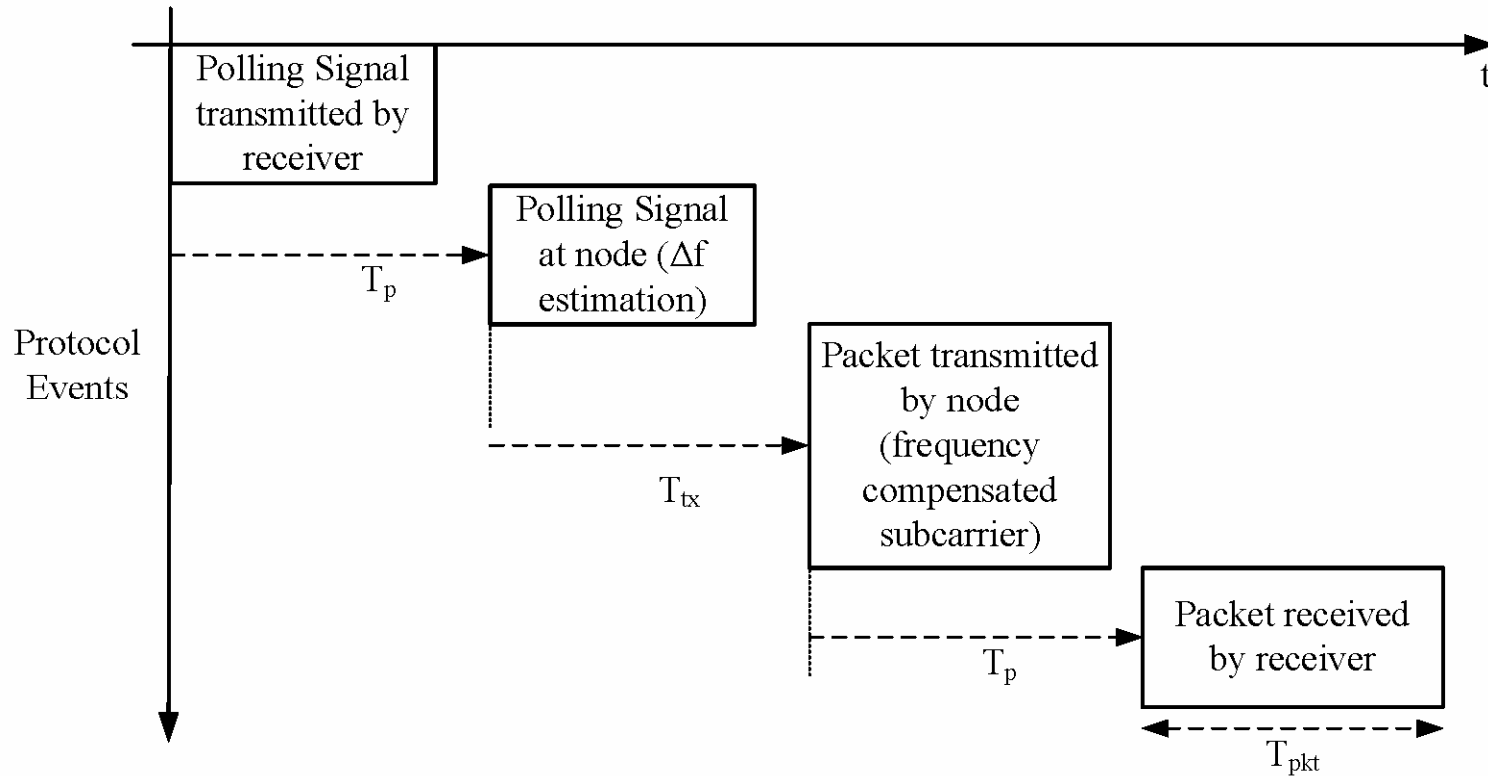

- *Quasi-synchronous* – all users transmit at approximately the same time
- Frequency offsets compensated in user transmitter

# Orient-2 limitations

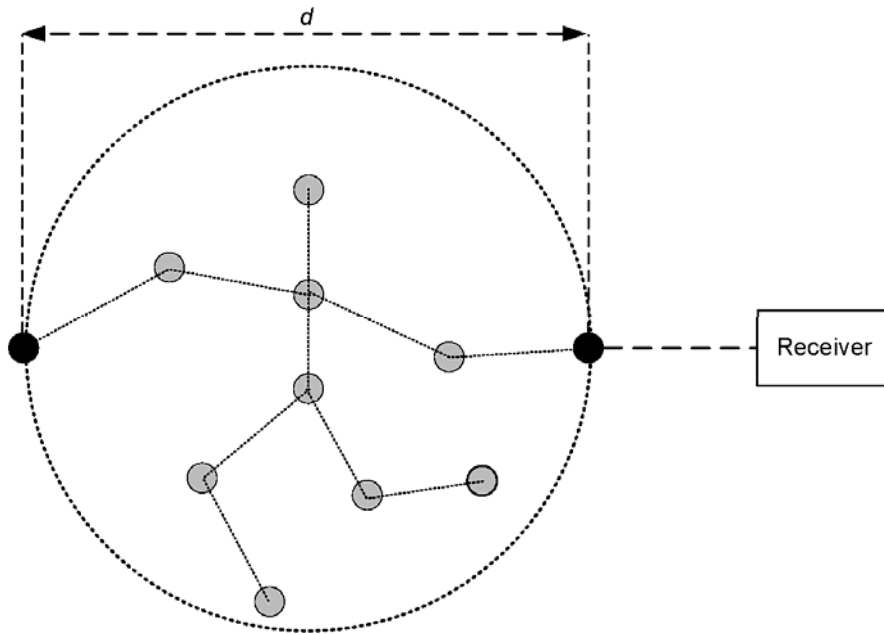

- Simple 2D representation
- 20kbps, time offset  $< 0.1\%$ , maximum node separation of **15m**.
- Negligible Doppler if maximum change in velocity over exchange period  $< 30\text{ms}^{-1}$

# Transmitter implementation

- Offset estimation
- Subcarrier synthesis

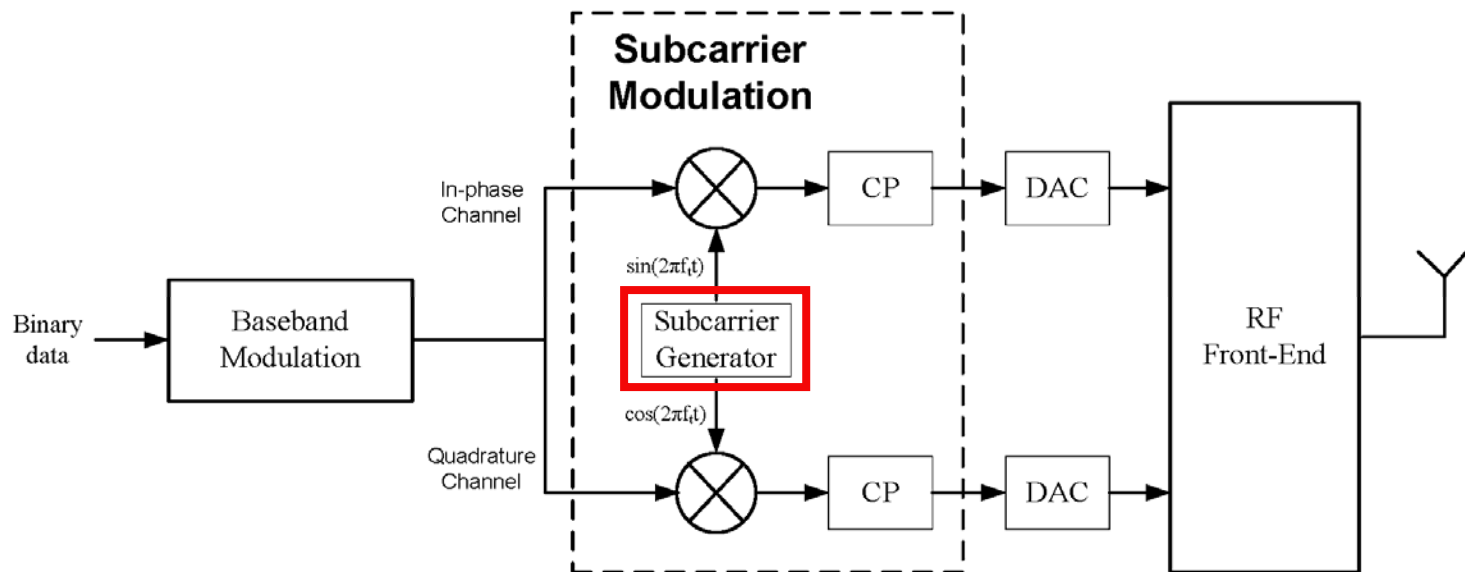

# Source of the frequency offset

$$\Delta f = \text{Doppler Offset} + \text{Carrier Offset}$$

Negligible

Estimate and correct

- Errors in estimation and synthesis remain
  - Residual error
$$\Delta f_r = \Delta f_{r,est} + \Delta f_{r,syn}$$
  - Depends on the accuracy of the estimate and synthesised signal

# Accuracy of freq estimation and synthesis

- Analysis of interference due to frequency offsets taken from zero-mean Gaussian distribution

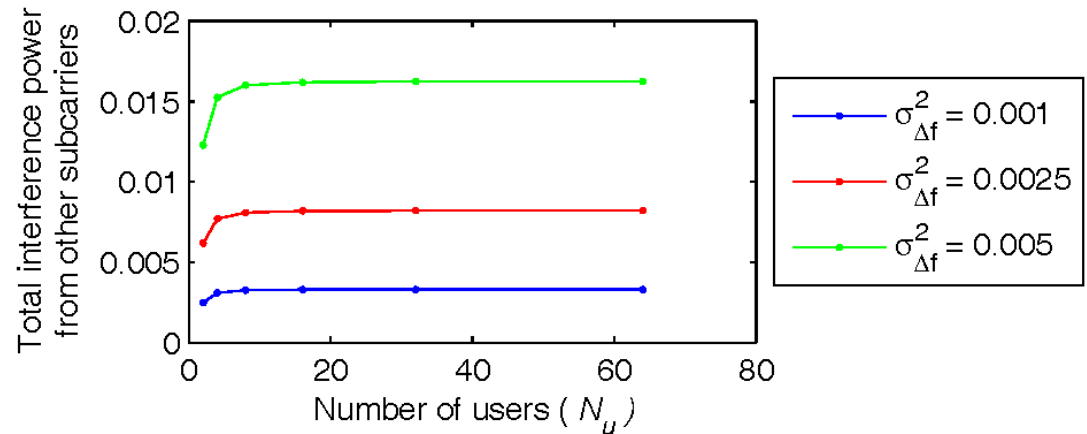
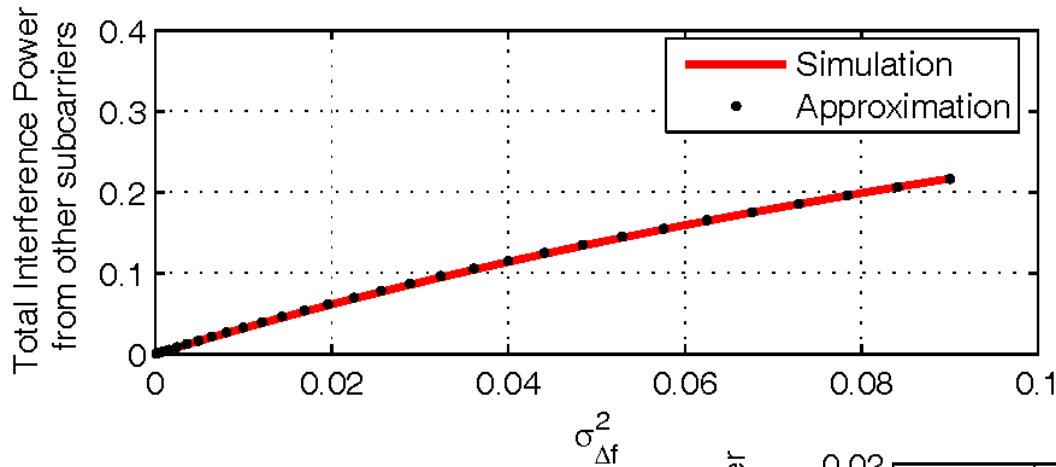

# BER degradation

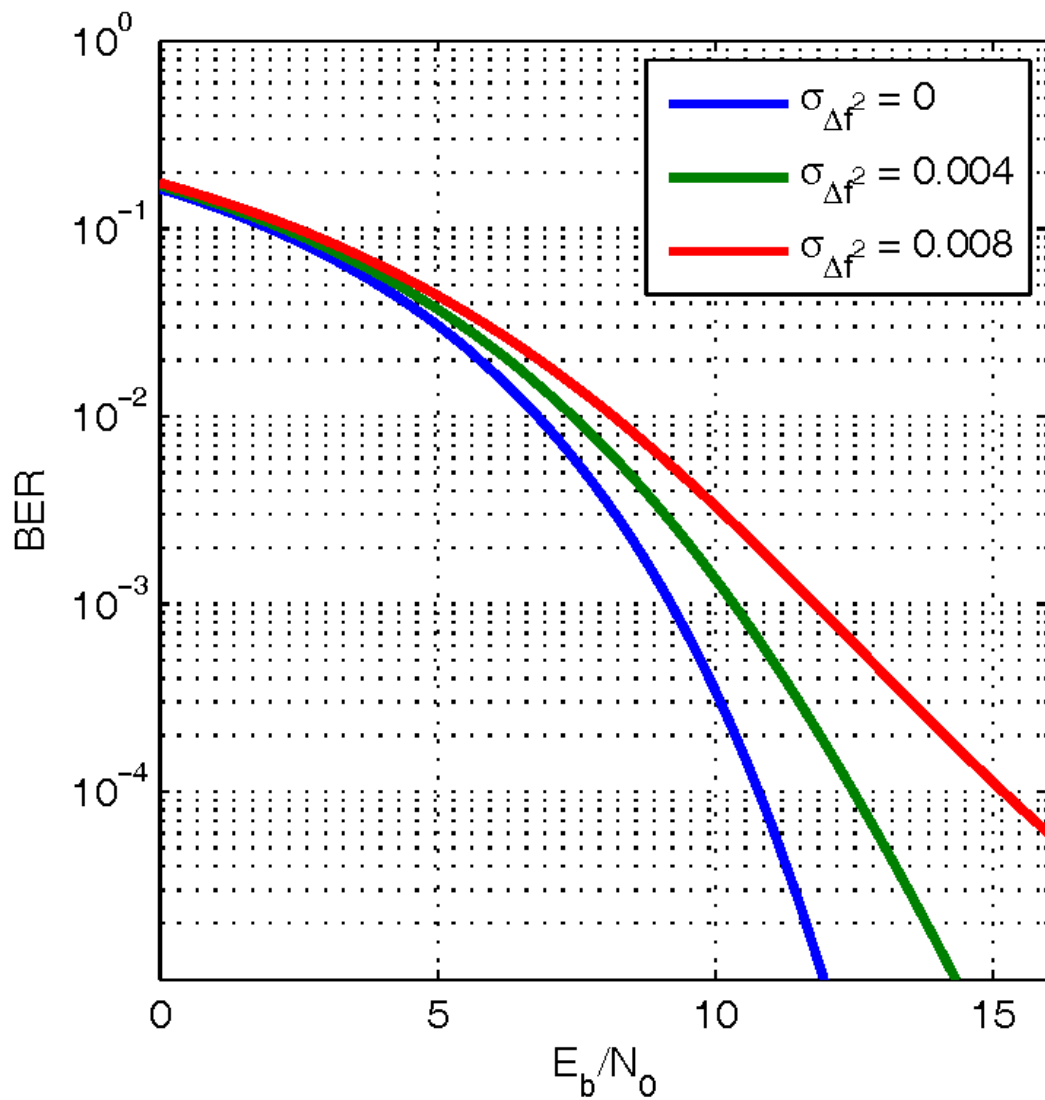

$$\frac{\overline{E}_b(\Delta f)}{N_0 + I_0(\Delta f)}$$

Offset Variance $\sigma_{\Delta f}^2$	$E_b/N_0$ Degradation (dB)
0.001	0.37
0.0025	0.99
0.005	2.24
0.0075	3.95

# Frequency Estimator

- Kay and Meyr estimators work on sample correlations

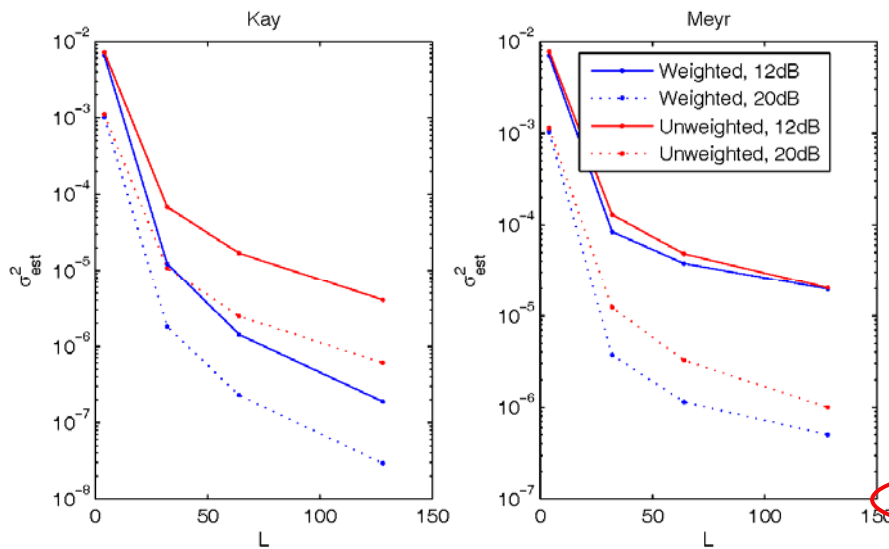

SNR(dB)	Estimator	L	D	Variance
12	Kay weighted	118	1	$2.45 \times 10^{-7}$
20	Kay weighted	64	1	$2.45 \times 10^{-7}$
20	Kay unweighted	203	1	$2.41 \times 10^{-7}$
20	Kay unweighted	146	2	$2.42 \times 10^{-7}$
20	Meyr weighted	92	2	$2.46 \times 10^{-7}$
20	Meyr unweighted	172	2	$2.46 \times 10^{-7}$

# Direct digital synthesiser (DDS)

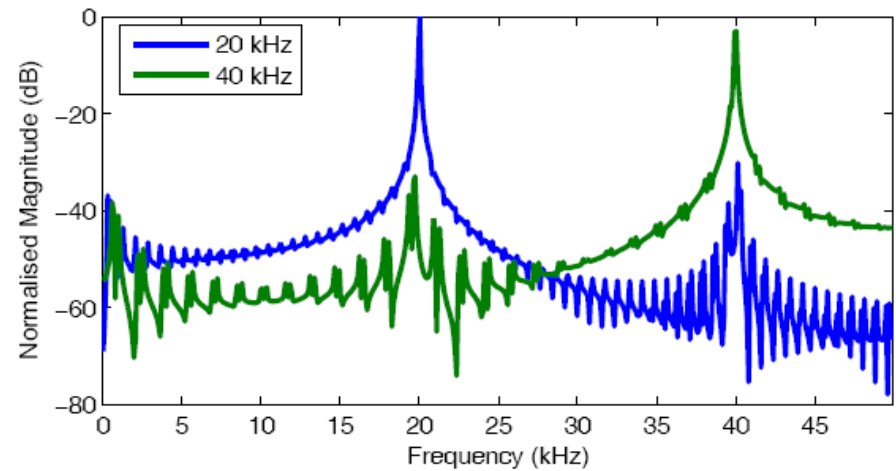
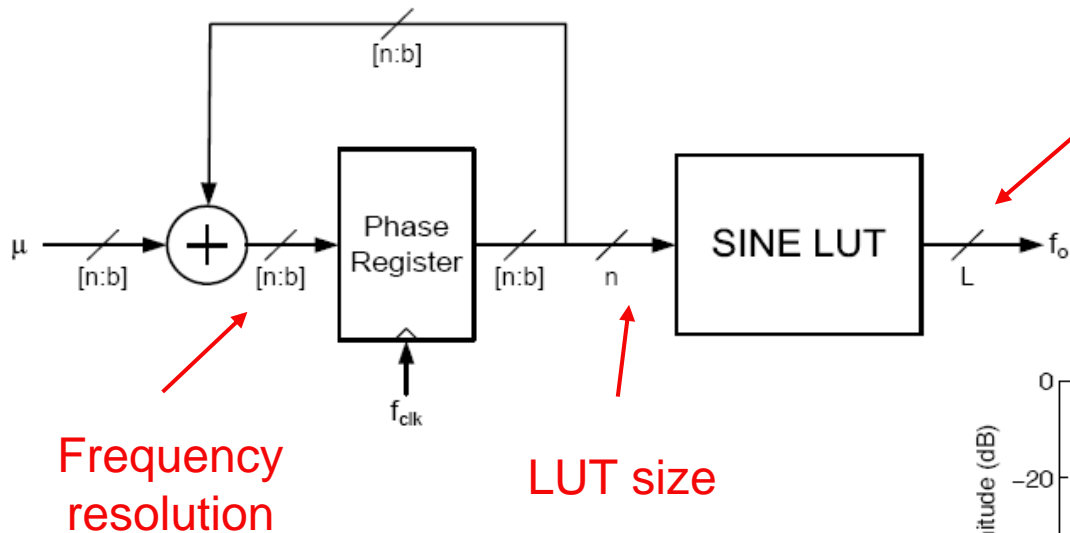

Parameter	Symbol	Unit	Value
Maximum frequency offset	$\Delta f_{max}$	kHz	200
Desired bit error rate	BER	-	$10^{-4}$
Sampling frequency /DDS clock frequency	$f_s/f_{clk}$	MHz	$\sim 1$
Subcarrier spacing	$f_{sub}$	kHz	10
Number of users/nodes	$N_u$	-	15

# Frequency resolution / accumulator wordlength

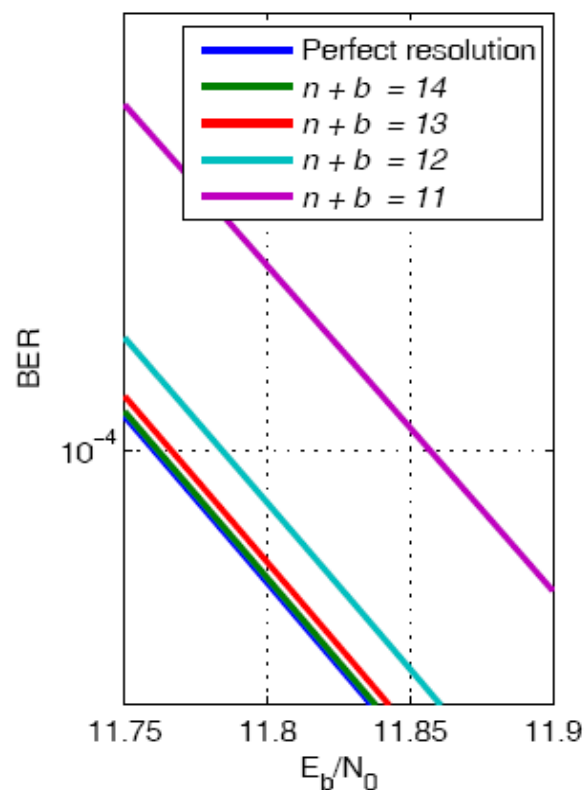
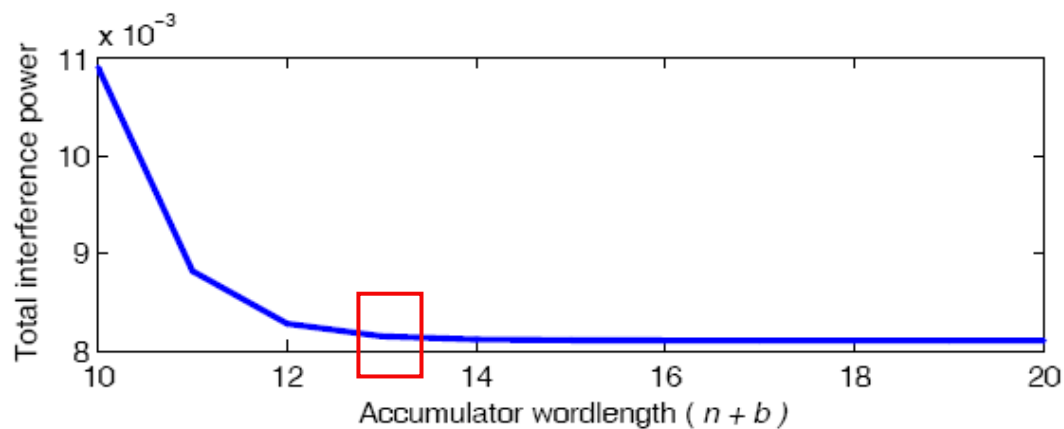

# Look-up table size

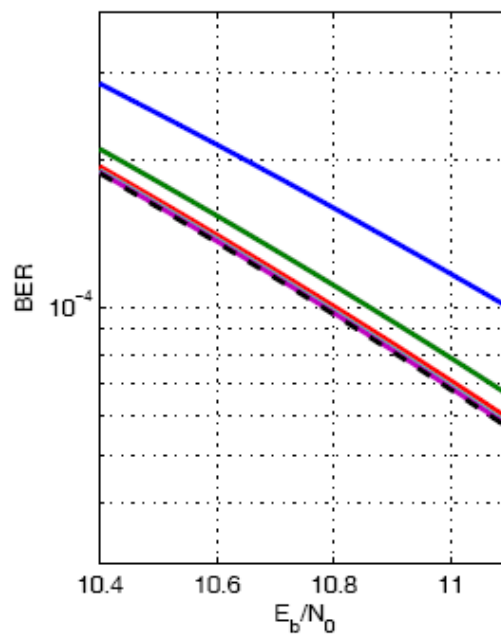
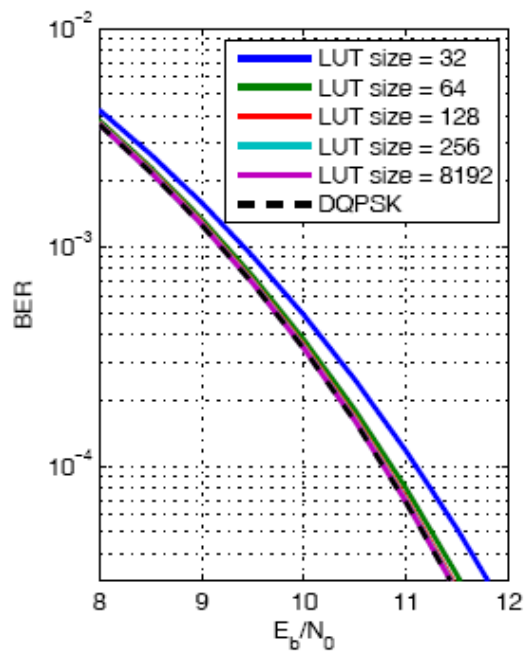
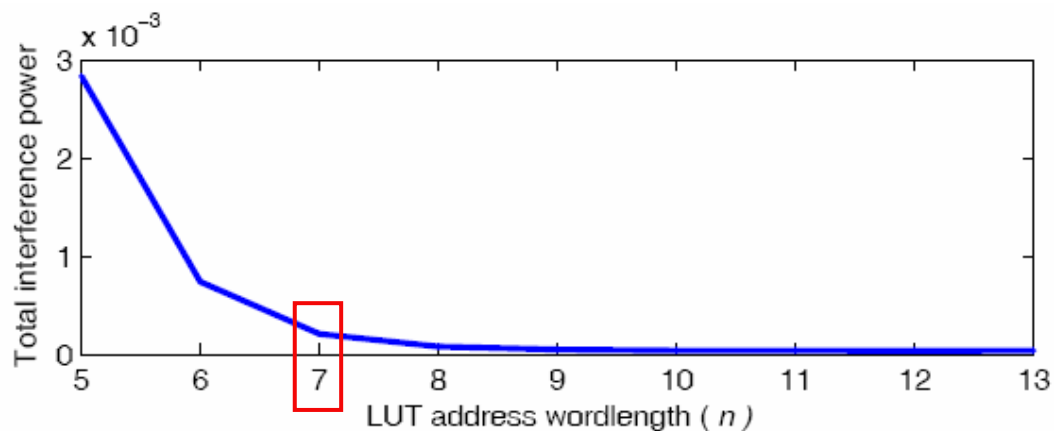

# Sine amplitude resolution

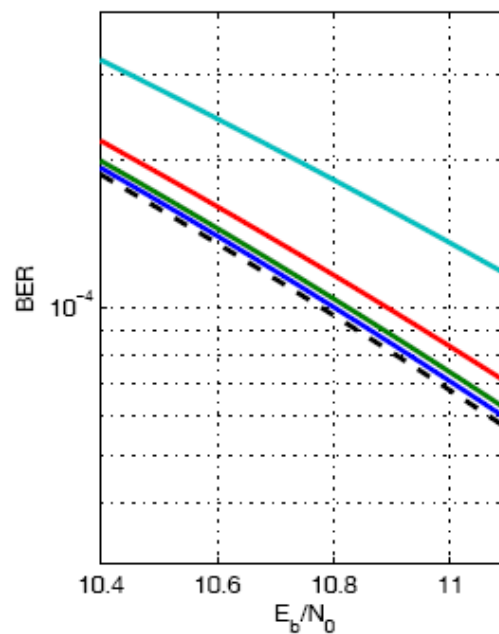
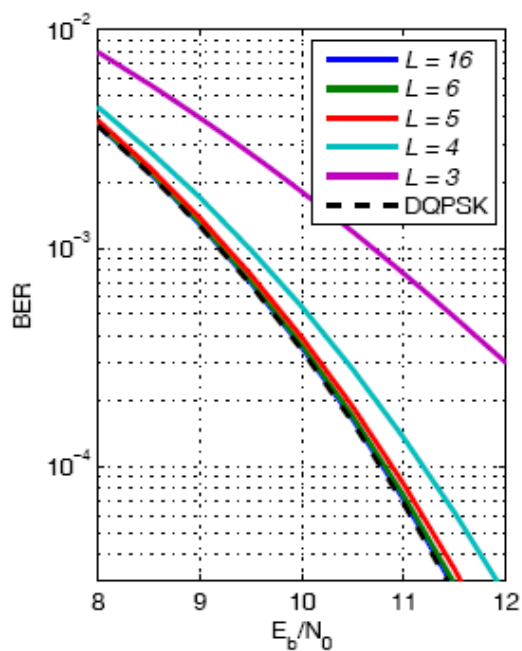
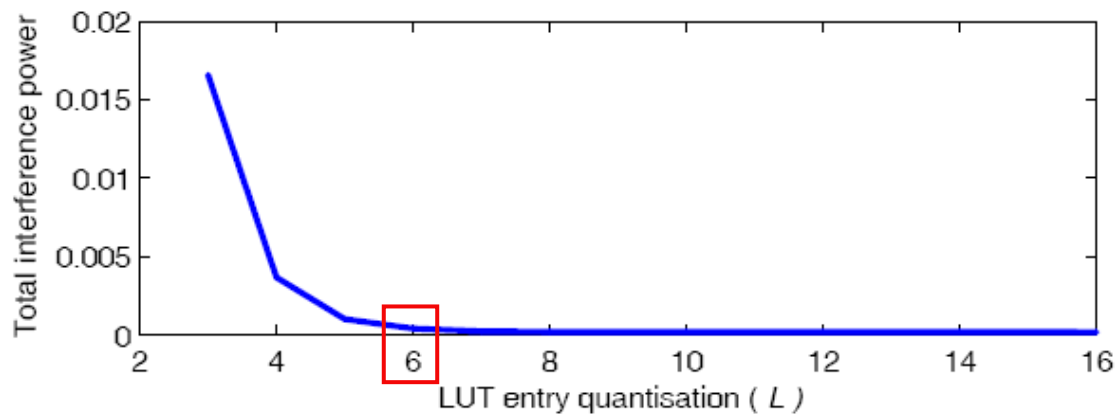

# Minimum complexity wordlengths

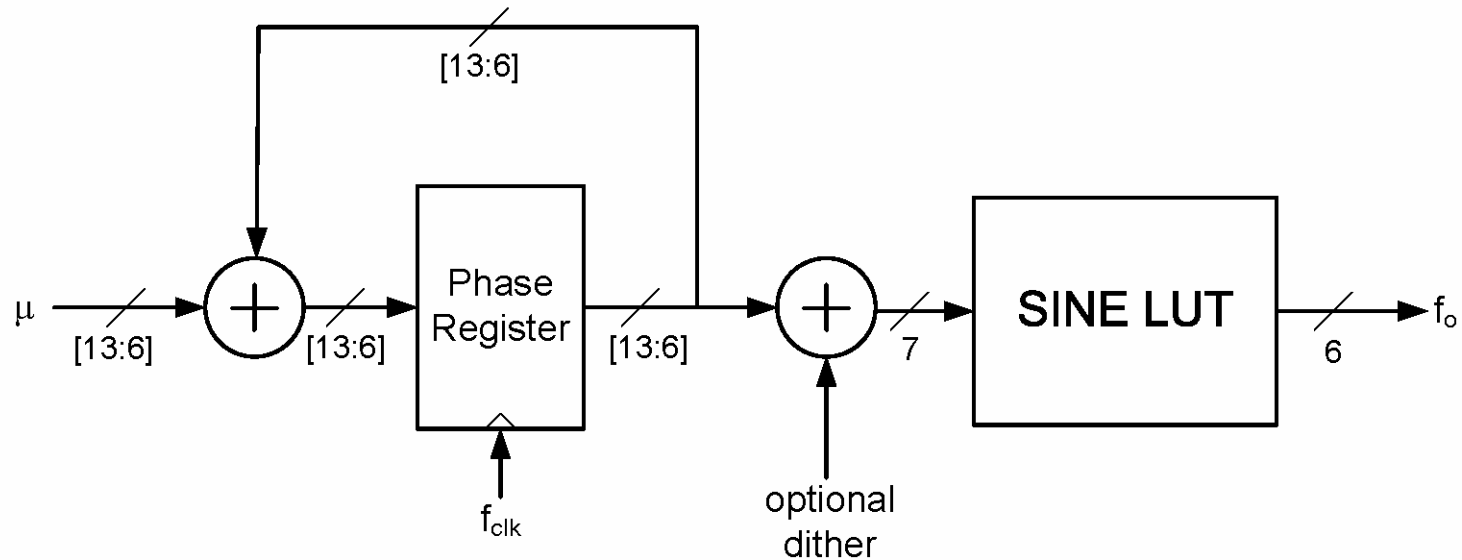

- 13 bit phase accumulator, resolution of 128Hz
- 128 entry LUT, 7 address bits
- 6 bit sine amplitude resolution

# Conclusions

- OFDMA-based data extraction protocol allows multiple nodes to communicate with a central receiver concurrently
  - Resolves previous issues with update rate and latency
- Elegant, fully digital architecture combines subcarrier modulation and frequency offset compensation
- Low-complexity implementation results in minimal performance degradation compared to the ideal case